



**Test Suite for the
CAx Interoperability Forum
Round 49J**

September 2021 – March 2022

Release 1.1

21 January 2022

Contacts

Jochen Boy
PROSTEP AG
jochen.boy@prostep.com

Jacques Heinisch
AFNeT Services
jacques.heinisch@afnet-services.fr

Phil Rosché
ACCR, LLC.
phil.rosche@accr-llc.com

Robert Lipman
NIST
robert.lipman@nist.gov

Table of Contents

1	Introduction.....	3
1.1	Functionality tested in this round	4
1.2	General testing instructions for this round.....	5
1.3	Testing Schedule.....	5
1.4	Copyrights on Test Cases	5
2	Synthetic Test Case Specifications	6
2.1	Test Case PMI: Semantic PMI Representation & Graphic PMI Presentation	6
2.2	APP: Assembly PMI Presentation.....	11
2.3	Test Case KM2: Kinematics.....	13
2.4	Test Case UD4: User Defined Parameters	17
2.5	Test Case AS3: AP242 Edition 2 Minor Revision Domain Model XML.....	20
2.6	Test Case CO4: Composite Part with Multiple Rosette	24
2.7	Test Case CO5: Composite Part with Rosette Guided by a Curve 90°	27
2.8	Test Case IO1: Alternative Part Shapes	29
Annex A	NIST Model Translation Configuration Considerations	32
Annex B	NIST Model Definitions.....	34

List of Figures

Figure 1:	CAx-IF Round49J Schedule	5
Figure 2:	Illustration of the "Vise" test model; Saved View "MBD_05".....	12
Figure 3:	Illustration of the KM2 test model with indicated kinematic pairs.....	15
Figure 4:	Overview on User-Defined Parameters and Properties defined in the test model ..	18
Figure 5:	Illustration of the Torque Converter model.....	21
Figure 6:	Torque Converter structure and indication if included attributes.....	22
Figure 7:	Illustration of the CO4 Test Case and Laminate Table.....	25
Figure 8:	Illustration of the CO5 Test Case.....	27
Figure 9:	Illustration (shape & colors) of IO1.....	30
Figure 10:	NX 8 vs. NX 9 Dimension Display Names	33

Document History

Release	Date	Change
1.0	2021-12-09	Initial Release
1.1	2022-01-21	Added APP test case for Assembly-level PMI Presentation Added CO5 test cases for Composite Rosette Guided by a Curve 90° Updated PMI Test Case to include Presentation Placeholder Updated Round 49J schedule

1 Introduction

The CAx Interoperability Forum (CAx-IF) is part of the Model-Based Interoperability Forum (MBx-IF), which is a joint effort between AFNeT, PDES, Inc. and prostep ivip. An interoperability forum is a logical collection of a user group and an implementer group, focused on specific capabilities of a named standard, in this case ISO 10303 STEP.

- The **User Group** is comprised of industry representatives, all members of at least one of the Interoperability Forum hosting organizations. The group will define and prioritize use cases, derive requirements and related validation properties as well as document user best practices.
- The **Implementor Group** is a group of software vendors, 3rd party integrators, and independent implementors, all members of at least one of the Interoperability Forum hosting organizations, that define recommended practices based on the prioritized use cases provided by the user group and validate them in test rounds.

The objectives of the CAx-IF concentrate primarily on testing the interoperability and compliance of STEP processors based on AP242 Ed. 1 & 2 and include documenting and prioritizing use cases, requirements and best practices to ensure completeness and consistency of the STEP standard and its implementations, implementing new functionalities based on users' requirements while ensuring these do not adversely affect existing implementations, avoiding roadblocks by establishing agreed-upon approaches, and increasing user confidence in STEP by providing interoperable commercial software products.

The CAx-IF's Implementor Group performs two test rounds per year for each domain and presents summary results to the user community. Furthermore, Recommended Practices are developed, and issues are reported to the standards development community.

The test rounds in general combine testing of synthetic and production models. Production models will in most cases be provided by the user companies of the organizations AFNeT, PDES, Inc., and prostep ivip Association. When production models are not available from the user companies, "production-like" models will be solicited from the various CAx-IF participants.

This test suite includes synthetic models for testing the following capabilities: Product Manufacturing Information (PMI), both as Graphic Presentation and as Semantic Representation, 3D Tessellated Geometry, Kinematics, Composite Materials, Assembly Structure with External References in AP242 Domain Model XML format, and Persistent Entity IDs.

1.1 *Functionality tested in this round*

Functionality tested in this round relates to:

- **Product Manufacturing Information (PMI)** describes the capability to embed information about dimensions, tolerances and other parameters which are necessary input for the manufacturing and measuring of the part from the 3D model. In this round, the focus will be on the two approaches for the transfer of PMI in the 3D model:
 - “Tessellated Presentation” refers to breaking down each annotation into tessellated elements as supported by AP242 and exchanging them as geometry. This preserves the exact shape of the annotation but is human readable only.
 - “Assembly-level Presentation” applies the concept above to assemblies, where PMI elements are defined between different parts, or part instances. Concepts such as Saved Views and Cross-Highlighting shall work in the same way.
 - “Semantic Representation” refers to the intelligent transfer of PMI data in an associative and reusable way. This scenario aims towards driving downstream usage and later modifications of the model. The data is machine-readable, but not necessarily visible in the 3D model. The test also includes additional presentation data, which can be linked to the corresponding PMI representation.
- **AP242 Domain Model XML** is an implementation format introduced with AP242, and the designated process format for many applications in the aerospace and automotive industries. It will be used in combination with geometry formats matching the respective requirement. In the CAX-IF, the geometry files will be in STEP Part 21 format. The XML files contain the assembly structure and part master information. The tests, which are conducted jointly with the PDM-IF, primarily aim at improving CAX-PDM interoperability by ensuring that the different types of systems correctly cope with the different levels of information.
- **Composite Materials** are made by layering various plies of material on top of each other. They can be defined in an implicit-precise way, by giving the laminate tables, ply boundaries, orientation, materials, and laminated cores; or in an explicit-tessellated way by calculating the resulting 3D Tessellated Solid. Both representations can be linked to each other.
- **Kinematics** is a capability in AP242 that allows describing the motion of parts over time and in relation to each other. This includes the definition of mechanisms with joints and constraints, defining the kinematic relationships between the parts, as well as motions, which are defined by capturing the positions of the moving parts at discrete points in time. To cover Aerospace as well as Automotive use cases, and to increase the range of participating systems, this capability is being tested jointly with the JT-IF.
- **Persistent Entity IDs** enable the ability to track a product’s model information during design iteration, and from design iteration through to manufacturing and quality analysis. This will allow downstream systems to update their representations of the design model and update their manufacturing and metrology planning to reflect changes in the design.
- **User Defined Parameters** at the part level as well as at the geometry level are used to convey data that drives certain aspects of a model, e.g., geometric features, or engineering notes and requirements that manufacturing must comply with. This may also include custom-defined properties. A target application shall be able to pick up on these and make appropriate decisions for downstream processes.
- **Alternative Part Shapes** is a capability that allows for storing several different representations of the same part in a single file. This approach can be applied at various levels in the model structure, supporting a range of use cases. In Round 49J, the focus is on providing a precise B-Rep shape and a tessellated shape for the same part.

1.2 General testing instructions for this round

The general procedures for communication of models and statistics are outlined in a separate document, entitled 'General Testing Instructions'. The document can be retrieved from the CAx Interoperability Forum web sites. The latest version is v1.13, dated September 29, 2017.

1.3 Testing Schedule

The following schedule has been agreed upon for Round 49J:

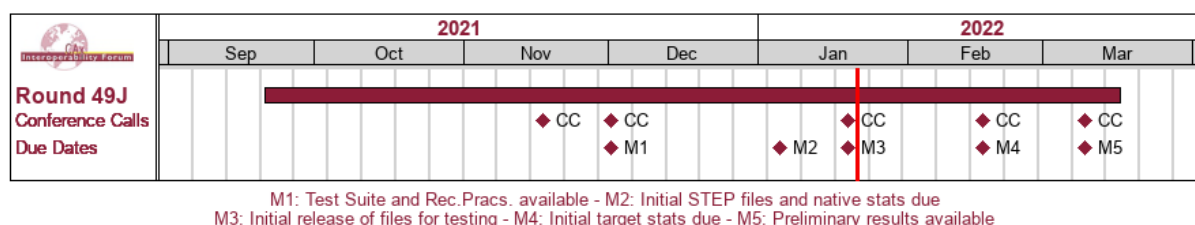

Date	Action
17 Nov 2021 (Wed)	Round 48J Follow-up / Round 49J Preparation Call
1 Dec 2021 (Wed)	1st CAx-IF Round49J Conference Call / Test Suite and Rec.Pracs. available
5 Jan 2022 (Wed)	Initial STEP files and native stats due
19 Jan 2022 (Wed)	2nd CAx-IF Round49J Conference Call / Initial release of files for testing
16 Feb 2022 (Wed)	3rd CAx-IF Round49J Conference Call / Initial target stats due
9 Mar 2022 (Wed)	4th CAx-IF Round49J Conference Call / Preliminary results available
14 Mar 2022 (Mon) - 16 Mar 2022 (Wed)	CAx-IF Round49J Review Meeting in Cyberspace

Figure 1: CAx-IF Round49J Schedule

The test round review meeting in March will once again be held fully online, due to the ongoing pandemic and related travel restrictions.

1.4 Copyrights on Test Cases

1.4.1 CAx-IF

None of the production test cases which were provided by the AFNeT, PDES, Inc. and prostep ivip member companies may be publicly released for any purpose. The test cases can be freely distributed among the CAx-IF members and can be used for any purposes that are related to CAx-IF testing (i.e. testing, documentation of testing efforts, etc.), if a reference to the originating company is made.

The test cases must not be used for any purposes other than CAx-IF testing or outside of AFNeT, PDES, Inc. and prostep ivip. Test cases provided by the LOTAR project for testing of specific capabilities are applicable to the same restrictions and may not be used outside LOTAR or the CAx-IF.

1.4.2 NIST

The test cases developed at the National Institute of Standards and Technology (NIST) are not subject to copyright protection and are in the public domain. NIST assumes no responsibility for the components of the test system for use by other parties and makes no guarantees, expressed or implied, about their quality, reliability, or any other characteristic. The use of the CAD systems to create the Test Models does not imply a recommendation or endorsement by NIST.

For more details, read the disclaimer at <http://go.usa.gov/mGVm>

2 Synthetic Test Case Specifications

2.1 Test Case PMI: Semantic PMI Representation & Graphic PMI Presentation

All information about this test case can also be viewed in CAESAR on its Information page.

2.1.1 Motivation

Product Manufacturing Information (PMI) is required for numerous business use cases in the context of STEP data exchange. Among others, it is a prerequisite for long-term data archiving. In addition, PMI can be used to drive downstream applications such as coordinate measuring and manufacturing.

Semantic PMI Representation relates to the capability to store PMI data in the STEP file in a computer-interpretable way, so that it can be used for model redesign or downstream applications. Though the definition of the data is complete, it is by itself not visible in the 3D model.

In addition to use cases that require a fully defined, precise, semantic definition of the part geometry and associated PMI, there are also scenarios where the presentation of the data – geometric elements and annotations – for visual consumption are the primary goal. In such cases, a simplified and optimized version of the model is sufficient. The tessellated geometry model included in AP242 provides an efficient mechanism to support this.

A wide variety of test models is available from NIST as well as prostep ivip, each containing a different selection of PMI elements. Each model is typically concentrated on specific subsets of PMI data.

2.1.2 Approach

The approach to be used is described in the latest version (at least v4.0.8, dated 4 September 2020) of the “Recommended Practices for Representation and Presentation of PMI (AP242)”, which can be found in the CAX-IF member area under “Information on Round46J of Testing”.

Within the PMI domain, the following functionalities are in scope of Round 49J:

- Semantic PMI Representation
- Tessellated PMI Presentation
- Correct implementation and definition of the Saved Views (view layout and contents)
- Linking of PMI Representation to Presentation
- Transfer of editable PMI text as User Defined Attributes
- PMI Validation Properties (Representation & Presentation)
- (New) Presentation Placeholder (including Placeholder Leader Lines if supported)

The AP242 schema to be used is the AP242 Edition 2 IS schema, which is available on the CAX-IF homepages under “Public Testing Information”.

Note: To ensure full support of the latest changes and additions in the Recommended Practices, the recommended schema is the final draft longform schema for AP242 Edition 2 Minor Revision, which is available in the CAX-IF member area under “Information on Round 48J of Testing”.

Pre-checking of files with SFA: All vendors generating STEP files for the SP7 test case shall run them through the latest version of NIST’s STEP File Analyzer and Viewer (SFA; currently version 4.66). Use the Syntax Checker in SFA to check for basic syntax errors such as missing and malformed entity instances. Files with such errors will not be accepted for testing.

SFA can be downloaded for free at <https://go.usa.gov/yccx/>

2.1.3 Testing Instructions

The tests will be performed based on a verified set of test models, each with set of well-defined PMI elements. In Round 49J, the models developed in the context of the “MBE PMI Validation and Conformance Testing” project will be used again, as they have been designed with emphasis on specific PMI capabilities.

2.1.3.1 NIST Test Model Overview

The NIST models are constantly updated to the latest CAD software releases by the respective system vendors, in order to improve the definition of the models using the latest CAD system capabilities.

The links to the test model definitions, the NIST web page for the MBE PMI Validation and Conformance Testing Project, and illustrations of the 11 test cases can be found at the end of this document in Annex B.

2.1.3.2 NIST Test Model Access

The updated native CAD files can be downloaded using the hyperlinks in the list below:

- [CATIA V5-6R2019](#)
- [Creo 4](#)
- [NX1980](#) (*updated from NX12*)
- [Inventor 2021](#)

Even though many updates have already been made by the respective system vendors, a number of verification issues remain to be solved. Should new native models with further updates become available during the test round, they will be distributed and announced accordingly.

2.1.3.3 NIST Test Model Selection

A subset of the NIST test cases has been selected for Round 49J:

- **FTC-6:** Datum targets (lines and curves), radius, more holes
- **FTC-7:** PMI validation properties, dimensions, position tolerances and surface profile tolerances
- **FTC-8:** Complex and stacked feature control frames, mix of tolerances and modifiers
- **FTC-9:** Perpendicularity on hole diameter (every vendor had a different solution)
- **FTC-10:** Datum features and Datum targets; mix of tolerances and modifiers
- **FTC-11:** Dimension average, roundness tolerance

Note that the only change in this list is the addition of FTC-11, which has not been formally tested before. To help with prioritization, a list with noteworthy issues has been provided by Bob Lipman and is available as an annex to the Round 48J Meeting Minutes in the CAX-IF member area.

Note that to keep the workload within reasonable bounds, PMI validation properties will be formally evaluated only on FTC-7.

Note that vendors are encouraged to submit STEP files for all 11 NIST test cases, for investigation by Bob Lipman. However, only STEP files for the five models listed above will be distributed for testing in Round 49J and their respective results evaluated on CAESAR.

2.1.4 Test Model Configuration

The following functionality shall be included in the test files provided for this round of testing, as far as it has been implemented by the CAX-IF participants and is described in the Recommended Practices:

- **PMI Representation** – the re-usable representation of PMI data should be included in all PMI models to the extent supported by the native system.
- **PMI Tessellated Presentation** – Many CAD systems require some minimal presentation information to be able to handle the PMI data in a model. Usually, both PMI representation and presentation data are included in the same file. Thus, some form of presentation information shall be included in the PMI test case as well.
- **PMI Presentation Placeholder** – This information enables a target system with PMI authoring capability to recreate the presentation of a PMI element based on its Semantic Representation data. It intends to provide a minimal set of presentation information to CAD systems, which require information such as the leader line attachment point on the part geometry to create the corresponding Semantic PMI Representation elements.
 - Implementation of this capability requires the AP242 Ed.2 Minor Revision long-form EXPRESS Schema, provided in the CAX-IF member area under “Information on Round 48J of Testing”, as well as the corresponding excerpt from the upcoming version 4.0.10 of the PMI Recommended Practices, which is available under “Information on Round 49J of Testing”.
- **Definition of “Saved Views”** – as far as supported, include the saved views defined in the models, which contain a subset of annotations in the file, and provide a pre-defined position of the model in the design space.
 - All models have multiple Saved Views defined. In the test case definition documents, each page of the PDF document represents one Saved View.
 - For each view, a screenshot showing the model layout (displayed elements, orientation, zoom) shall be provided.

Note that it is possible to attach several screenshots to one set of statistics in CAESAR. The name of the view shall be given as description for the screenshot.

 - Both “basic” and “advanced” view implementations are allowed.
 - The Saved Views shall correctly show (or hide) the part geometry, as well as the non-solid Supplemental Geometry contained in some of the models (see section 9.4.2 / Figure 93 in the PMI Rec. Practices v4.0.8). A document pointing out important supplemental geometry elements for the NIST test cases is available in the CAX-IF member area, under “Information on Round 42J of testing”.
- **Editable PMI Text** – Some information relevant for PMI is not encoded in semantic entities, but given as plain text, such as the title block information or additional text on feature control frames. In the context of semantic data exchange, this content needs to be editable in the target system. The approach to be used for this is based on the transfer of User Defined Attributes, and its application in the context of PMI is described in section 7.4 of the PMI Recommended Practices v4.0.8.
- **Linking PMI Representation to Presentation** – If a model contains PMI Representation information as well as Presentation data, the corresponding elements shall be linked together, so that a Representation element “knows” which annotation it is being presented in the model. The approach to create this link is described in section 7.3 of the PMI Rec. Pracs. (v4.0.8).

- Cross-highlighting of annotations and annotated shape – if supported, include in the STEP file the information necessary to maintain the association between graphic annotations and the annotated shape elements in a way, that after import, when highlighting an annotation, the shape elements annotated by it are highlighted too, and vice versa.
- Validation Properties – All participants providing STEP files for this test case are encouraged to include validation properties for PMI semantic representation and graphic presentation, as defined in the PMI Recommended Practices v4.0.8, sections 10.1 and 10.2 respectively.
 - **Note** that in Round 49J, PMI validation properties will be formally evaluated only on the FTC-7 test case.
- Presentation Placeholder – As extension of the scope in Round 49J, STEP files created for the PMI test case shall also include Presentation Placeholders per section 7.2 in the PMI Recommended Practices (v4.0.10), as far as supported by the translator.

Vendors are encouraged to also include definitions of the placeholder leader lines (section 7.2.4), though these are not mandatory for an initial implementation of the placeholder. Note that to implement placeholder leader lines, the AP242 Edition 2 Minor Revision EXPRESS schema is required, which is available in the CAX-IF member area under “Information on Round 48J of Testing”.

Also refer to Annex A for test model translation configuration considerations.

2.1.5 Statistics

For each STEP file exported or imported for the PMI test case, vendors must submit the corresponding statistics. To do so, go to the [PMI Data Sheet], and either fill in the web form, or upload a comma-delimited file (.csv) with the data as listed below.

Native Statistics

When exporting a STEP file, report what data importing systems should expect to find. For numeric statistics, enter the respective value or 'na' if not supported. For other statistics, select either 'full support' (i.e. test case and Rec. Pracs. definitions are fulfilled), 'limited support' (meaning the implementation does not meet all criteria and issues may be expected on import), or 'na' if not supported.

Target Statistics

When importing a STEP file, report the results after processing the file as described below.

Screenshots

For each Saved View in the model, provide one screenshot, which illustrates the layout (displayed geometry and annotations, model orientation, and zoom factor). Give the name of the view as the description of the screenshot. Note that CASEAR allows the addition of multiple screenshots per dataset.

Note that in order to count the GD&T elements for the statistics, per agreement during the R22J Review Meeting, the actual STEP entity types (`datum`, `datum_target...`) shall be considered.

Note that based on the Round 35J results, a new count has been added for Composite Tolerances as defined in section 6.9.9. of the PMI Rec. Pracs. (v4.0.8).

Note that all statistics – native and target – shall be based on the Semantic PMI Representation data only, and not take any presentation into account.

Note that for evaluation, the spreadsheets generated by the STEP File Analyzer and Viewer will be amended with corresponding aggregations of relevant counts and charts.

Data Sheet Columns

column name	description
model	The name of the test model, here 'pmi', with one of the following suffixed: 06, 07, 08, 09, 10.
system_n	The system code of the CAD system creating the STEP file
system_t	The system code of the CAD system importing the STEP file. For native stats, select 'stp'
scope	A short designation for the contents of the model as defined in the Test Suite. This is for information only; there will be no results for this field.
dimensions	The number of dimensions processed
datums	The number of datums processed
datum_targets	The number of datum targets processed
tolerances	The number of tolerances (all types combined) processed, regardless of composition.
compos_tols	The number of composite tolerances processed (number of instances of geometric_tolerance_relationship per section 6.9.9. in the PMI Rec. Pracs. v4.0.8).
labels	The number of labels processed
pmi_semantic_txt	all/partial/none – whether 'semantic' (editable) PMI text was transferred correctly (content and associativity)
pmi_semantic_val-prop	all/partial/none – whether the validation properties for Semantic PMI Representation matched for all, some or none of the semantic PMI elements.
saved_view	The name of the Saved View which is the basis for the view-related statistics
view_annot	The number of annotations included in the specified saved view.
view_pos	pass/fail, whether the model orientation and zoom factor stored for the Saved View could be restored successfully.
elem_visibility	all/partial/none – whether all, some, or none of the elements to be displayed in the indicated saved view were mapped correctly into the corresponding draughting_model.
highlight	all/partial/none – whether the cross-highlighting for annotations and annotated shape elements works correctly
pmi_graphic_pres	all/partial/none – whether the graphic PMI annotations included in the file could be processed correctly
pmi_present_val-prop	all/partial/none – whether the validation properties for Graphic PMI Presentation matched for all, some or none of the presentation elements.
pmi_linked_pres_rep	all/partial/none – whether the Semantic PMI Representation elements and (Graphic) PMI Presentation elements were linked correctly together.
pmi_pres_placeholder	all/partial/none - whether all, some, or none of the PMI Presentation Placeholders in the file were processed correctly.
date	The date when the statistics were last updated (will be filled in automatically)
issues	A short statement on issues with the file

2.2 APP: Assembly PMI Presentation

All information about this test case can also be viewed in CAESAR on its Information page.

2.2.1 Motivation

So far PMI information – Graphic Presentation and Semantic Representation – has been dealt with mostly in the context of single parts. There is also the need to transfer PMI data in the context of assemblies. While in general, the PMI elements created in an assembly context are very similar to those created on single parts, the assembly structure adds additional levels of complexity:

- The target geometry for any PMI element needs to be identified within the correct instances of the target components within the assembly structure.
- For any Saved View defined at the assembly level, the appropriate scope of geometry needs to be included. This may include the full assembly, or only some of the components.
- All of this also needs to work across several files, to support the “nested assembly” approach.

Previous LOTAR pilots in the scope of LOTAR Part 125 have proven the concepts defined so far. These initial tests were based solely on one CATIA assembly. The next step is to test this capability on a broader scale in the CAX-IF, with a test model available in various native formats.

2.2.2 Approach

The approach to be used for Assembly-level PMI Presentation is defined in the PMI Recommended Practices, v4.0.8, which is available in the CAX-IF member area archive, under “Information on Round 46J of Testing”.

The approach needed for the APP test case in Round 49J is described in section 9.3.4, “Linking Annotations with Component Instances (Assembly PMI)”.

In Round 49J the tests shall be done using the “all-in-one” approach, i.e., exporting a single AP242 Part 21 file containing.

Possible future extension of this test case may include hiding a component in an assembly-level Saved View (PMI Rec. Pracs. section 9.4.2.3) as well as moving on to the “nested” approach (PMI Rec. Pracs. section 9.4.2.4 and External Element References document v3.2).

2.2.3 Testing Instructions

The APP test case in Round 49J will use the “Vise” test model, courtesy of prostep ivip. This model is an assembly consisting of four parts with part-level PMI, which has been tested in the CAX-IF before.

For the purpose at hand the model has been extended to include PMI elements as well as a Saved View at the assembly level.

The native files for the “Vise” test model can be found in the File Repository within the CAX-IF member area, folder CAD/Round 49J/Vise. The model is available in three formats:

- CATIA V5 R30
- Creo 7
- NX 12

A PDF document with information about the included PMI is available in the same location.

Some of the assembly-level PMI might be academic, but this model has been deemed fit for the purpose until more industry-level multi-format assembly PMI test models become available.

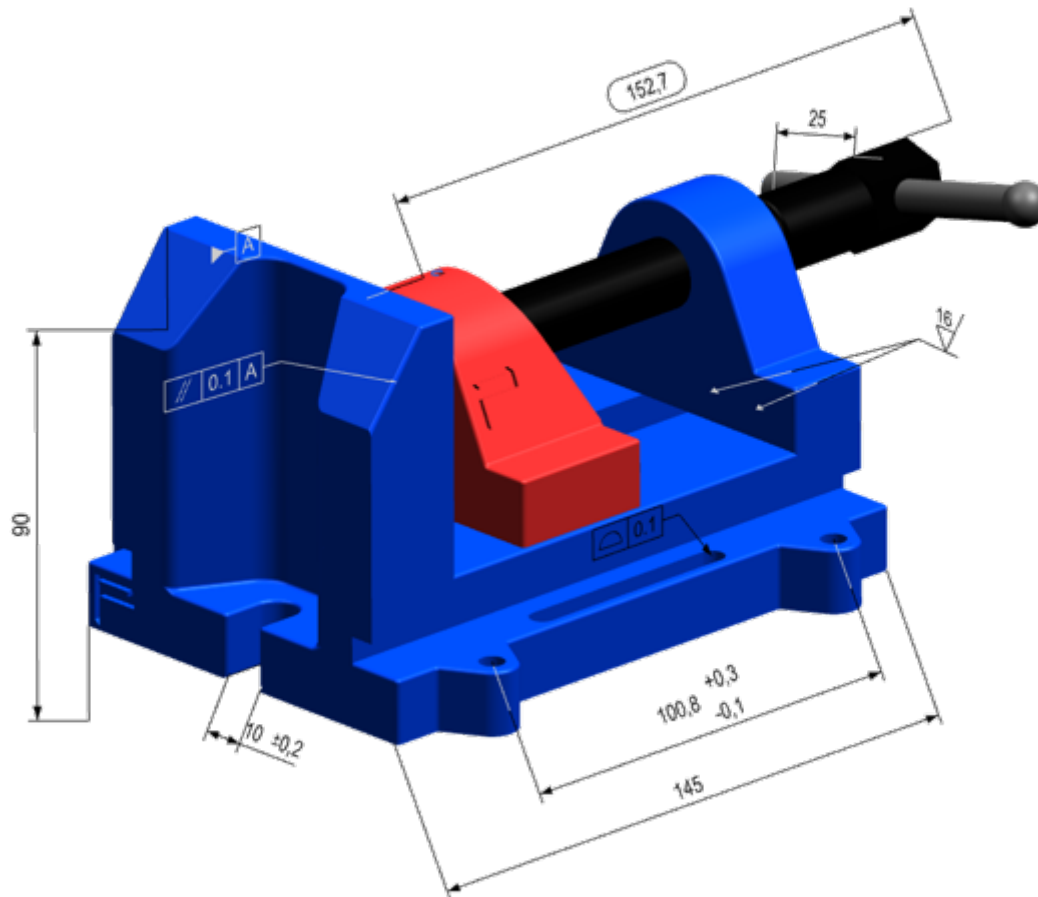

Figure 2: Illustration of the "Vise" test model; Saved View "MBD_05"

2.2.4 Statistics

For each STEP file exported or imported for the APP test case, vendors must submit the corresponding statistics. To do so, go to the [APP Data Sheet], and either fill in the web form, or upload a comma-delimited file (.csv) with the data as listed below.

Native Statistics

When exporting a STEP file, report what data importing systems should expect to find. For numeric statistics, enter the respective value or 'na' if not supported. For other statistics, select 'full support' (i.e. test case and Rec. Pracs. definitions are fulfilled), 'limited support' (meaning the implementation does not meet all criteria and issues may be expected on import), or 'na' if not supported.

Target Statistics

When importing a file, report the results found after processing the file as described below.

Data Sheet Columns

column name	description
model	The name of the test model, here 'km2'
system_n	The system code of the CAD system creating the STEP file
system_t	The system code of the CAD system importing the STEP file. For native stats, select 'stp'
saved_view	The name of the Saved View which is the basis for the view-related statistics
view_annot	The number of annotations included in the specified saved view.
dimensions	The number of dimensions processed
datums	The number of datums processed
tolerances	The number of tolerances (all types combined) processed, regardless of composition.
labels	The number of labels processed
view_pos	pass/fail, whether the model orientation and zoom factor stored for the Saved View could be restored successfully.
elem_visibility	all/partial/none - whether all, some, or none of the elements to be displayed in the indicated saved view were mapped correctly into the corresponding draughting_model.
highlight	all/partial/none - whether the cross-highlighting for annotations and annotated shape elements works correctly
pmi_present_valprop	all/partial/none - whether the validation properties for Graphic PMI Presentation matched for all, some or none of the presentation elements.
date	The date when the statistics were last updated (will be filled in automatically)
issues	A short statement on issues with the file

2.3 Test Case KM2: Kinematics

All information about this test case can also be viewed in CAESAR on its Information page.

2.3.1 Motivation

CAD methods have been used for many years now to design individual parts and assemblies of all sizes across all industries, from a single rivet to an entire airplane. Classically the main focus is to ensure that the part can be manufactured correctly.

Products such as cars, planes or assembly lines are not static, however, contain many moving components: engine, power windows, foldable roof, windshield wipers, cargo doors, etc. Thus, Kinematics are used to ensure they move correctly, as well as to illustrate the behavior of the finished product. The use cases cover the definition of the Kinematic Mechanism, providing all relationships and constraints between the elements so that their definition can be changed in the receiving application.

The goal is to use a neutral standard format – AP242 Edition 2 Domain Model XML – for the definition of the Kinematic mechanisms, with external references to the applicable geometry format for the respective use case.

2.3.2 Approach

The following schemas and documents shall be used for this test:

- Recommended Practices for AP242 Edition 2 Minor Revision Domain Model XML Kinematics, version 1.0, dated 26 November 2021, available on the public CAx-IF homepage under "CAx Recommended Practices".
- AP242 Edition 2 Minor Revision Domain Model XML, dated 11 May 2021, available in the CAx-IF member area under "Information on Round 48J of Testing". *If the schema is not yet available at the final URL stated in the Recommended Practices, please use a local copy of the schema.*

The Kinematic capabilities for AP242 XML are developed jointly by the CAx-IF and the JT-IF, thus supporting Aerospace as well as Automotive requirements, and broadening the scope of participating STEP translators. To ease the exchange of the files, the part geometry files for the KM2 test model are available in STEP AP242 Part 21 as well as ISO JT (JT v9.5) format, so the AP242 XML file references can easily be adapted for the preferred geometry format.

Based on this approach, Kinematic test files...

- ...from JT-IF Round 22 (August - November 2021) will be carried over to CAx-IF R49J.
- ...from CAx-IF R49J will be handed over to JT-IF Round 23 (February – June 2022).

2.3.3 Testing Instructions

In Round 49J, the Kinematics test model originally developed by Stefani Maschinenbau and provided by Audi and Volkswagen via the prostep ivip / VDA JT Workflow Forum will be used again. It represents a gripper tool used in a production line assembly. This production-like model is used for internal pilot projects at Volkswagen and Audi and is being shared with the implementor forums for testing exclusively within these groups.

- The native CATIA version of the "Gripper" has been modeled by :em engineering methods on behalf of Audi. The ZIP package also contains an HTML breakdown of the model contents, also created by :em engineering methods.
- The native NX version of the "Gripper" has been modeled by Siemens PLM on behalf of Audi.
- The native CATIA and NX models are available in the CAx-IF member area under "Information on Round 48J of testing". Please make sure to use the latest version (upload date 6 July 2021).

Note that the models also contain PMI but checking these is out of scope for the KM2 test case, which solely focuses on the Kinematic definitions.

The following is in scope of Round 49J:

- Kinematic Mechanism includes the definition of kinematic pairs (joints and constraints) and actuators. The goal is that the mechanism is editable in the target system, while preserving the dependencies defined in the original system.
- Assembly & Kinematic Data shall be provided in a single AP242 XML file.
- Geometry shall be included as STEP AP242 Part 21 precise B-Rep files.

Note that the Kinematic capabilities are tested in cooperation with the JT Implementor Forum in order to increase the number of participating systems and to enable exchange of data between different systems. This requires replacing the geometry files as well as the file references in the AP242 XML file but has no impact on the actual Kinematic capabilities.

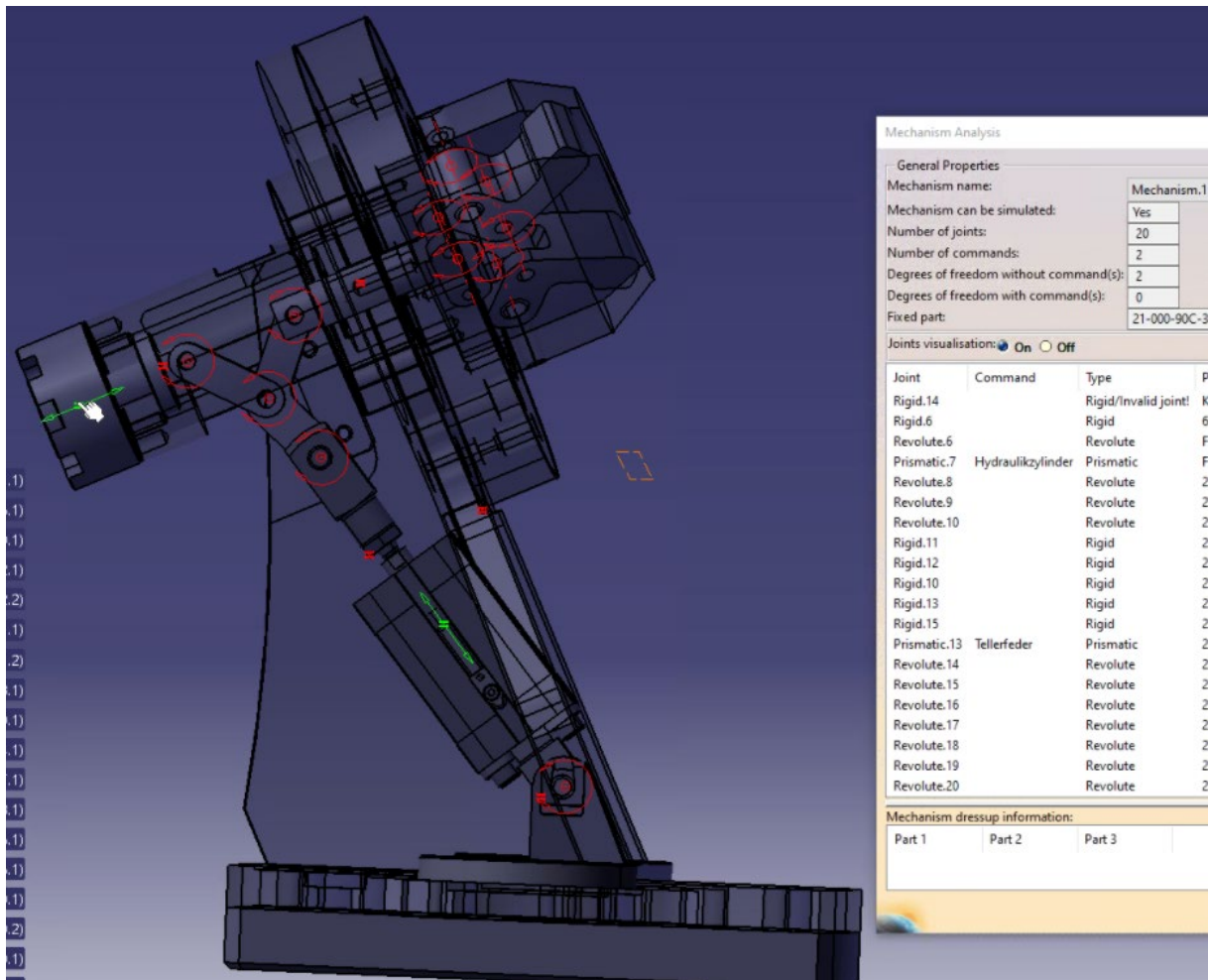

Figure 3: Illustration of the KM2 test model with indicated kinematic pairs

2.3.4 Statistics

For each STEP file exported or imported for the KM2 test case, vendors must submit the corresponding statistics. To do so, go to the [KM2 Data Sheet], and either fill in the web form, or upload a comma-delimited file (.csv) with the data as listed below.

Native Statistics

When exporting a STEP file, report what data importing systems should expect to find. For numeric statistics, enter the respective value or 'na' if not supported. For other statistics, select 'full support' (i.e. test case and Rec. Pracs. definitions are fulfilled), 'limited support' (meaning the implementation does not meet all criteria and issues may be expected on import), or 'na' if not supported.

Target Statistics

When importing a file, report the results found after processing the file as described below.

Kinematics-specific Statistics

For more detailed information about and discussion of in the Kinematics-specific statistics, please refer to section 4.12 of the Kinematics Recommended Practices mentioned above.

Data Sheet Columns

column name	description
model	The name of the test model, here 'km2'
system_n	The system code of the CAD system creating the STEP file
system_t	The system code of the CAD system importing the STEP file. For native stats, select 'stp'
assem_struct	pass/fail – if the model structure (assembly tree) was transferred correctly, i.e. no nodes have been added or removed, and all elements are on the correct hierarchical level.
kin_mechanisms	The number of Kinematic Mechanisms defined in the model
kin_moving_parts	Number of moving parts in a Kinematic Mechanism
kin_mech_pairs	The number of low/high order Kinematic Pairs defined for a Kinematic Mechanism
kin_placements	The number of AxisPlacements used by KinematicPairs
kin_revolute_pairs	The number of Revolute Pairs defined for Kinematic Mechanisms
kin_planar_pairs	The number of Planar Pairs defined for Kinematic Mechanisms
kin_cylindrical_pairs	The number of Cylindrical Pairs defined for Kinematic Mechanisms
kin_mech_acts	The number of Kinematic Pairs that have a non-zero value in the attribute 'actuation', i.e. where an initial movement can occur
date	The date when the statistics were last updated (will be filled in automatically)
issues	A short statement on issues with the file

2.4 Test Case UD4: User Defined Parameters

All information about this test case can also be viewed in CAESAR on its Information page.

2.4.1 Motivation

CAD models often contain user-defined parameters which define additional properties on the part. These can be parameters which drive the geometry (parametric definition), or engineering notes, requirements and custom properties that are relevant for downstream processes such as manufacturing.

These properties are typically authored in the source CAD systems and need to be transferred in a way that target applications can identify and process them in such a way that they make the appropriate decisions and derive relevant information for downstream use.

The CAX-IF User Group has defined several user stories related to user-defined properties and user-defined parameters at the part level as well as at the geometry level. The UD4 test case in Round 49J serves as an acceptance test for these user stories.

While the exact naming, structuring and association of these parameters to model elements – at part level as well as geometry level – differs between the different CAD systems based on their respective internal data models, they can be mapped to common concepts in STEP.

2.4.2 Approach

The approach for transferring user-defined properties and parameters with STEP AP242 is described in the “Recommended Practices for User Defines Attributes”, version 1.8 (18 February 2021), which is available on the public web site of the CAX-IF Implementor Group. Specifically, section 5.3 of this document, which was newly introduced with version 1.7, provides the necessary classification mechanism to properly identify user-defined parameters and properties.

The precise mapping recommendation for testing user defined properties and parameters in Round 49J is as follows (all based on section 5.3 of the Recommended Practices):

- `id_attribute.attribute_value = 'general property'`
- `property_definition.description =`
 - 'customized PDM property' (for user defined properties)
 - 'user defined attribute' (for user defined parameters)

The schema to be used is the AP242 Edition 2 IS schema, available in the public area of the CAX-IF Implementor Group web page.

2.4.3 Testing Instructions

The CAX-IF User Group has provided a set of native CATIA V5 test models with pre-defined parameters and properties. These are available in a ZIP package from the member area of the CAX-IF web sites, under “Information on Round 47J of Testing.”

- The test model "ParameterTestPart_simplified.CATPart" contains the basic parameters described in Figure 4 below.
- In addition, the test model "Parameter Test Part.CATPart" contains the complete set of Parameters/Properties that can be used.

Note that while it is the intention to test this capability across different CAD systems, the CAX-IF user group so far provided native models only for CATIA V5. Thus, in Round 49J:

- CATIA / 3DEXPERIENCE – STEP interfaces shall map the user defined properties and parameters as defined above, maintain their semantics on export and import
- STEP translators for other CAD systems shall import the generated files and report their experiences on how they map the data.

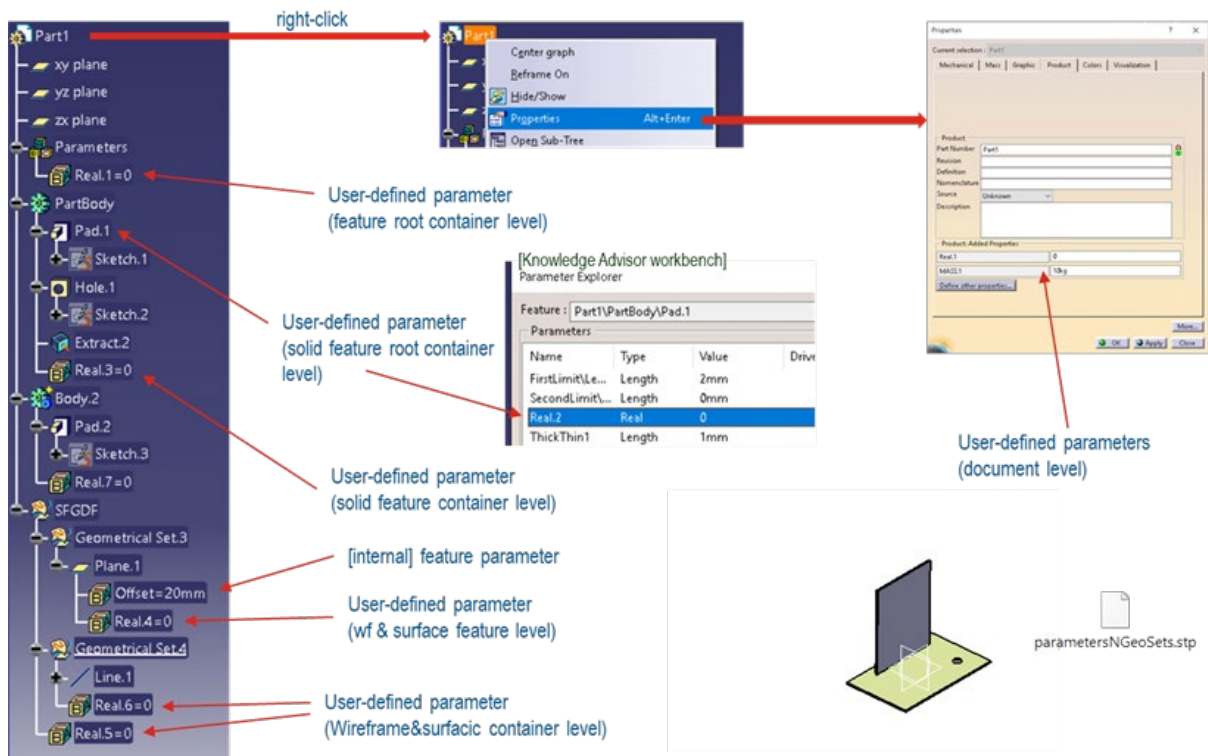

Figure 4: Overview on User-Defined Parameters and Properties defined in the test model

2.4.4 Statistics

For each STEP file exported or imported for the UD4 test case, vendors must submit the corresponding statistics. To do so, go to the [UD4 Data Sheet], and either fill in the web form, or upload a comma-delimited file (.csv) with the data as listed below.

Native Statistics

When exporting a STEP file, report what data importing systems should expect to find. For numeric statistics, enter the respective value or 'na' if not supported. For other statistics, select 'full support' (i.e. test case and Rec. Pracs. definitions are fulfilled), 'limited support' (meaning the implementation does not meet all criteria and issues may be expected on import), or 'na' if not supported.

Target Statistics

When importing a file, report the results found after processing the file as described below.

Data Sheet Columns

column name	description
model	The name of the test model, here 'ud4'
system_n	The system code of the CAD system creating the STEP file
system_t	The system code of the CAD system importing the STEP file. For native stats, select 'stp'
ud_param_part	pass / fail, have the user defined parameters at part / product level been transferred correctly?
ud_prop_part	pass / fail, have the user defined properties at part / product level been transferred correctly?
ud_param_solid	pass / fail, have the user defined parameters for solids been transferred correctly?
ud_param_geoset	pass / fail, have the user defined parameters for CATIA geometric sets been transferred correctly?
ud_param_scp	pass / fail, have the user defined parameters for surfaces, curves and points been transferred correctly?
valid_attr	pass/fail, is the instantiation of the User Defined Attributes as per the Recommended Practices?
uda_part_vp	pass/fail, has the number of User Defined Attributes at the Part/Product level been processed correctly? This includes UDA VP at assembly component instances and for groups of UDA.
uda_geo_vp	pass/fail, has the number of User Defined Attributes at the Geometry level been processed correctly?
uda_type_vp	pass/fail, has the number of User Defined Attributes per attribute type class (boolean/integer/real/string) been processed correctly?
date	The date when the statistics were last updated (will be filled in automatically)
issues	A short statement on issues with the file

2.5 Test Case AS3: AP242 Edition 2 Minor Revision Domain Model XML

All information about this test case can also be viewed in CAESAR on its Information page.

2.5.1 Motivation

The exchange of assembly structures with external references to geometry files is a long-used concept in the STEP multiverse, which has proven its value and stability in many business use cases. In addition to the long-used Part 21 representation, AP242 Edition 2 provides a Domain Model with a comprehensive data model in an XML representation.

AP242 XML is the designated standard process format for the automotive and aerospace industries and will be used together with various standardized and proprietary geometry file formats, depending on the actual use case. Over time, this test case evolved to include external references to 3D Tessellated Geometry, Assembly Validation Properties and User Defined Attributes.

The second edition of AP242 was published in April 2020, which brought with it many changes in the underlying architecture of the standard as well as extended functionalities. However, some limitations and issues remained with the data model. These have now been resolved with the AP242 Edition 2 Minor Revision (MR). While the standard document is currently going through the release process, the final implementation schemas and updated Recommended Practices are available for vendors to update their translators.

In Round 49J, this test case is dedicated to the migration towards AP242 E2 MR.

Only AP242 E2 MR files will be accepted for testing in the AS3 test case.

2.5.2 Approach

The following schemas and documents shall be used for this test:

- Recommended Practices for AP242 Edition 2 Minor Revision Domain Model XML Product and Assembly Structure, version 3.0, dated 23 November 2021, available on the public CAX-IF homepage under "CAX Recommended Practices".
- AP242 Edition 2 Minor Revision Domain Model XML, dated 11 May 2021, available in the CAX-IF member area under "Information on Round 48J of Testing". *As long as the schema is not yet available at the final URL stated in the Recommended Practices, please use a local copy of the schema.*

The focus of this test is the assembly structure exchanged in AP242 XML format. The test has the following degrees of freedom:

File structure:

- "all in one" - one XML file for the entire assembly structure, plus one STEP file per component part
- "nested" - one XML file for each node in the assembly tree, plus one STEP file per component part. Note that in this case, component parts with part-level User Defined Attributes require an additional Domain Model XML sidecar file containing these properties; see Recommended Practices section 9.3.

Geometry format:

- Precise B-Rep (STEP AP242) or Tessellated Geometry (STEP AP242)

2.5.3 Testing Instructions

The test model to be used in Round 49J is the "Torque Converter", known from previous Benchmarking activities. Native CAD files are available for it in the following formats:

- CATIA V5
- Creo
- NX

These can be found in the File Repository within the member area of the CAX-IF web sites, in the folder *"CAD/Round 41J/Torque Converter"*.

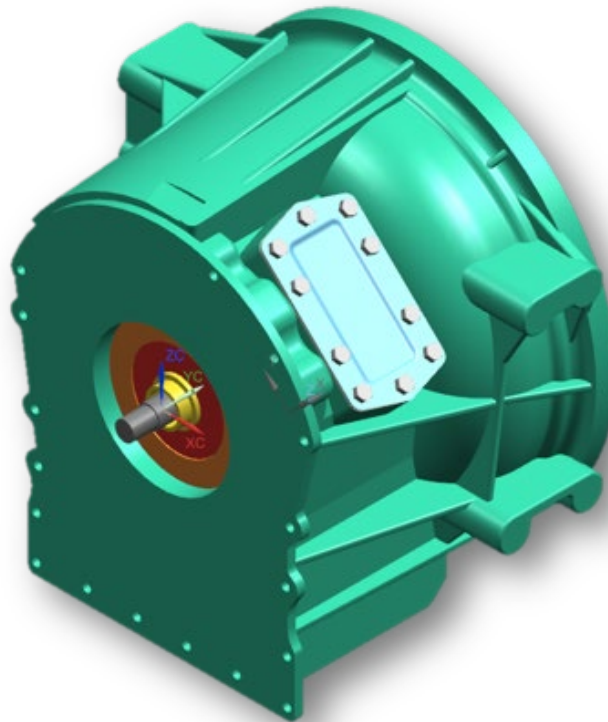

Figure 5: Illustration of the Torque Converter model

The aim of this test is to correctly transfer the assembly structure based on AP242 Edition 2 Minor Revision Domain Model XML files, using either the "all-in-one" or the "nested" approach, and referencing tessellated parts.

Since transfer of the AS3 geometry itself can safely be considered stable, there will be no geometry-related statistics. The evaluation will focus on completeness and correctness of the assembly structure and the external references.

The assembly files shall contain Assembly Validation Properties for all nodes in the product structure. The two values – number of children, and notional solids centroid – and their representation are defined in section 13.1 of the AP242 Edition 2 Minor Revision Domain Model XML Assembly Structure Recommended Practices.

In addition, all CAX-IF members supporting User Defined Attributes shall transfer the ones included in the native files (see below) at part level (section 12.5.1 of the Recommended Practices).

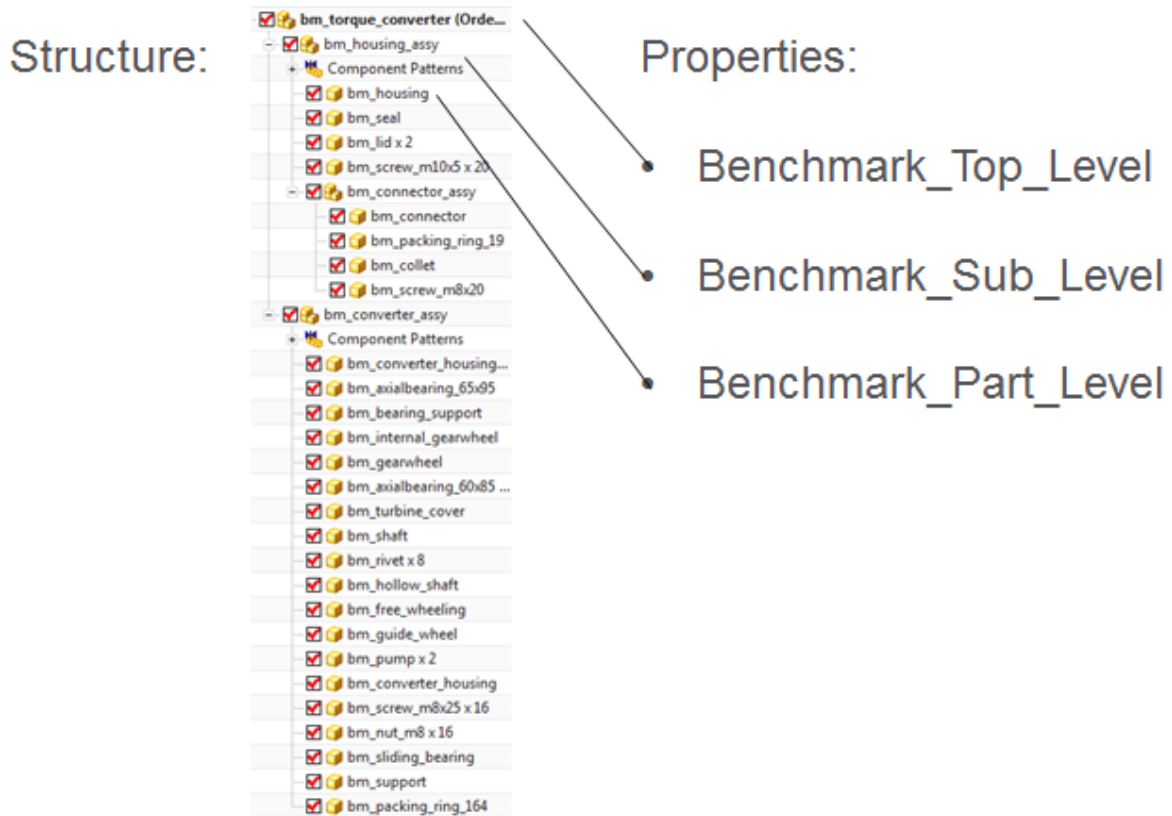

Figure 6: Torque Converter structure and indication if included attributes

2.5.4 Statistics

For each STEP file exported or imported for the AS3 test case, vendors must submit the corresponding statistics to CAESAR. To do so, go to the [AS3 Data Sheet], and either fill in the web form, or upload a comma-delimited file (.csv) with the data as listed below.

Native Statistics

When exporting a STEP file, report what data importing systems should expect to find. For numeric statistics, enter the respective value or 'na' if not supported. For other statistics, select either 'full support' (i.e. test case and Rec. Pracs. definitions are fulfilled), 'limited support' (meaning the implementation does not meet all criteria and issues may be expected on import), or 'na' if not supported.

Target Statistics

When importing a STEP file, report the results found after processing the file as described in the table below.

Data Sheet Columns

column name	description
model	The name of the test model, here: 'AS3'
system_n	The system code of the CAD system creating the STEP file
system_t	The system code of the CAD system importing the STEP file. For native stats, enter 'stp'
fref_found	all/partial/none - indicates if all, some or none of the references to the external files can be found in the assembly structure file(s), and if they are correctly associated with the respective nodes in the assembly structure.
fref_processed	all/partial/none - indicates if all, some or none of the referenced files were processed correctly to successfully construct the overall model.
assem_struct	pass/fail - if the model structure (assembly tree) was transferred correctly, i.e. no nodes have been added or removed, and all elements are on the correct hierarchical level.
assem_place	all/partial/none - whether the placement of assembly components is correct
children	pass/fail, indicates whether the number of children for each node in the assembly tree matches the AVP value given in the STEP file
valid_child	pass/fail, is the instantiation of the validation property 'number of children' in the STEP file as per the recommended practices for validation properties?
notional_solids	all/partial/none, whether the position of all, some or none of the assembly components in the model could be validated through the 'notional solids' AVP.
valid_notion	pass/fail, is the instantiation of the validation property 'notional solids' in the STEP file as per the recommended practices for validation properties?
part_attr	pass/fail, have the User Defined Attributes at the part/product level been processed correctly?
date	The date when the statistics were last updated (will be filled in automatically)
issues	A short statement on issues with the file

2.6 Test Case CO4: Composite Part with Multiple Rosette

All information about this test case can also be viewed in CAESAR on its Information page.

2.6.1 Motivation

For several years, some STEP composite interfaces have been available in several CAD tools such as CATIA V5, FiberSIM and in CT CoreTechnologie tools, with a certain level of maturity proven by LOTAR pilot projects.

The goal of including Composite Materials in a CAX-IF test round is to align these implementations and provide an official framework for composite materials implementation tests as STEP AP242 Edition 2 includes this capability.

The CAX-IF User Group created a user story with the requirement to convert a composite part with multiple rosettes within a ply group to STEP in a way that preserves the design intent.

2.6.2 Approach

For multiple rosettes inside the same ply group, the aim of the test is to take two plies inside the same ply group that do not have the same rosette, then to check that after STEP export/import that this is still the case.

As an example, in the given test case (see Figure 7 below),

- Ply “Ply.5” has the rosette “Rosette - Pad 1”
- Ply “Ply.6” has the rosette “Rosette - Pad 3”
- Plies “Ply.3” and “Ply.5” are both in the same group “Laminate Table 1 - Multiple Rosette Example”

The basis for implementation of the CO4 test case is the following:

- AP242 Edition 2 IS Longform Express Schema, available on the CAX-IF homepage under “Public Testing Information”.
- Recommended Practices for Composite Materials; Version 4.2; 17 August 2021; available on the public MBx-IF homepage under “CAX Interoperability Forum > Implementor Group > CAX Recommended Practices”.

2.6.3 Testing Instructions

The test case MultipleRosettesUseCase_RevA.CATPart will be used. The model has been provided by the CAX-IF User Group.

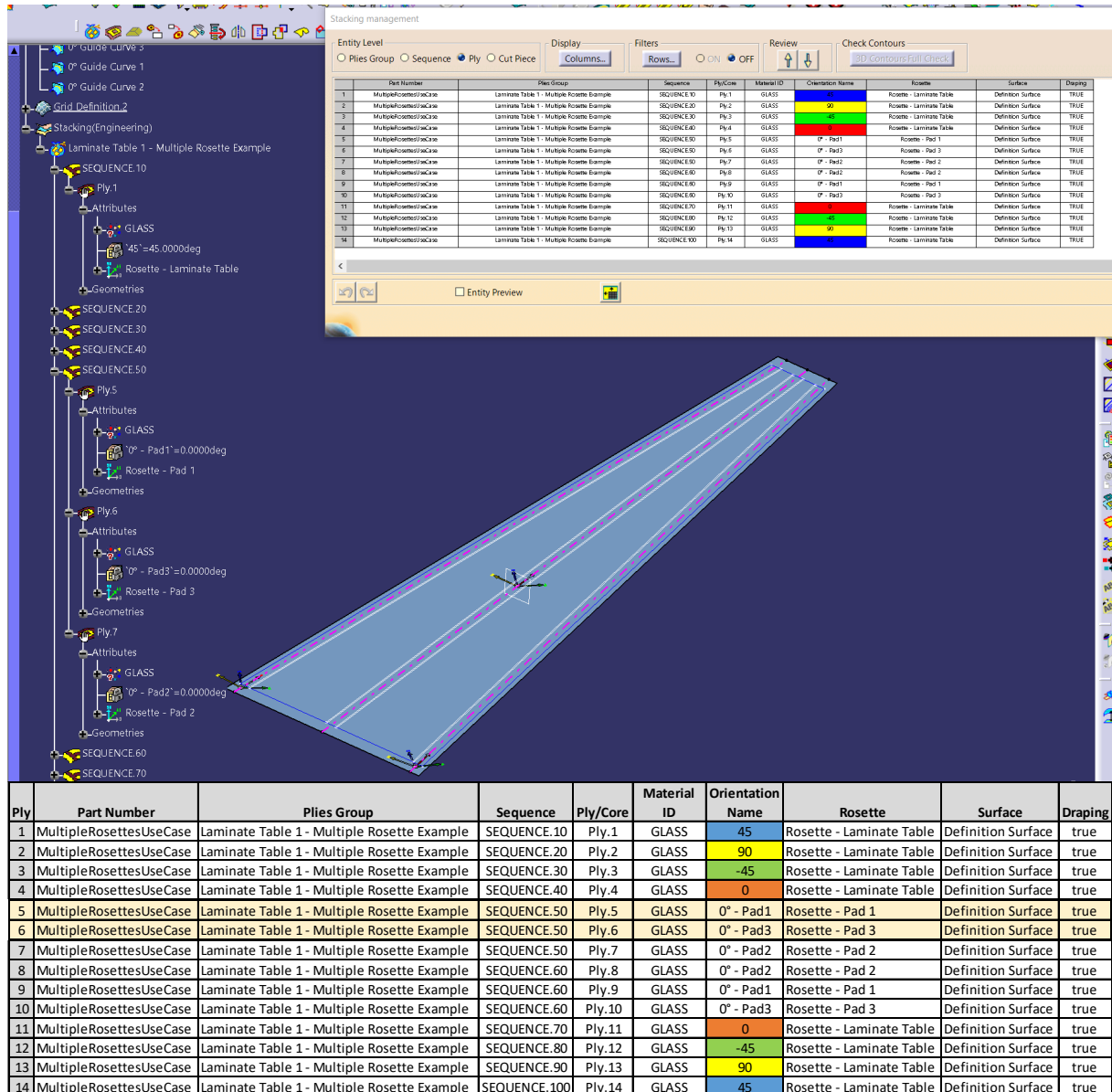

Figure 7: Illustration of the CO4 Test Case and Laminate Table

The test case is available in the member area of the CAX-IF homepages, under “Information on Round 48J of Testing”.

2.6.4 Statistics

For each STEP file exported or imported for the CO4 test case, vendors must submit the corresponding statistics. To do so, go to the [CO4 Data Sheet], and either fill in the web form, or upload a comma-delimited file (.csv) with the data as listed below.

Native Statistics

When exporting a STEP file, report what data importing systems should expect to find. For numeric statistics, enter the respective value or 'na' if not supported. For other statistics, select either 'full support' (i.e. test case and Rec. Pracs. definitions are fulfilled), 'limited support' (meaning the implementation does not meet all criteria and issues may be expected on import), or 'na' if not supported.

Target Statistics

When importing a STEP file, report the results found after processing the file as described in the table below.

Ply-related Statistics

Several of the Statistics for this test case are related to a specific ply within a specific sequence (e.g., material, orientation, rosette). The statistics cannot evaluate this for all plies in the model. Hence, the idea is to select one specific (interesting) sequence and ply on export, and to publish its name in the "Composite Ply Sequence" field of the statistics. Then, fill in the other ply-related statistics with the values as valid for this particular sequence and ply. After import, select the sequence and ply with the name given in the native statistics, and again provide the values valid for this particular sequence and ply.

The plies group to be used for evaluating the CO4 test case in Round 49J is:

Laminate Table 1 - Multiple Rosette Example

The plies to be used for evaluating the CO4 test case in Round 49J are:

PLY.5, PLY.6

Data Sheet Columns

column name	description
model	The name of the test model, here 'CO4'
system_n	The system code of the CAD system creating the STEP file
system_t	The system code of the CAD system importing the STEP file. For native stats, select 'stp'
unit	The unit the model is designed in
compos_tables	The number of Composite Tables in the Model
compos_table_name	The name of the Composite Table of the model
plies	The total number of plies in the model
plies_groups	The total number of plies groups in the model
rosettes_pg	The number of rosettes in the plies group selected for this test
multi_rosettes	pass/fail, do the selected plies within the same plies group have multiple rosettes assigned.
date	The date when the statistics were last updated (will be filled in automatically)
issues	A short statement on issues with the file

2.7 Test Case CO5: Composite Part with Rosette Guided by a Curve 90°

All information about this test case can also be viewed in CAESAR on its Information page.

2.7.1 Motivation

For several years some STEP composite interfaces have been available in several CAD tools such as CATIA V5, FiberSIM and in CT CoreTechnologie tools, with a certain level of maturity proven by LOTAR pilot projects.

The goal of including Composite Materials in a CAX-IF test round is to align these implementations and provide an official framework for composite materials implementation tests as STEP AP242 Edition 2 includes this capability.

The CAX-IF User group provided a user story including a composite part with Rosette Guided by a curve, where the primary direction is set to non-zero (i.e., 90°). The goal is to archive the data for certification, as well as exchanging it with a manufacturing supplier.

2.7.2 Approach

The aim of this test is to transfer the rosettes defined in the part, the relationship to the respective guide curve, as well as the respective orientation as defined in the native model.

The table in section 2.7.4 provides the details for the given test model.

The basis for implementation of the CO5 test case is the following:

- AP242 Edition 2 IS Longform Express Schema, available on the CAX-IF homepage under “Public Testing Information”.
- Recommended Practices for Composite Materials; Version 4.2; 17 August 2021; available on the public MBx-IF homepage under “CAX Interoperability Forum > Implementor Group > CAX Recommended Practices”.

2.7.3 Testing Instructions

The native model is the file "ASME_Y14.37_RosetteType2_90GuidedByCurve_A.CATPart", which is available in the member area of the CAX-IF homepage under "Information on Round 49J of Testing". This model has been provided by the CAX-IF User Group.

Type II – Guide Curve - 90 deg along curve

— 0 deg.
— 90 deg.

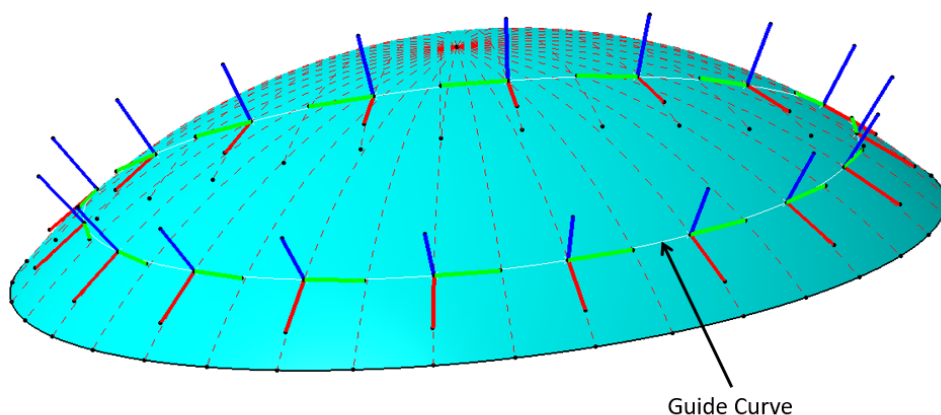

Figure 8: Illustration of the CO5 Test Case

2.7.4 Statistics

For each STEP file exported or imported for the CO5 test case, vendors must submit the corresponding statistics. To do so, go to the [CO5 Data Sheet], and either fill in the web form, or upload a comma-delimited file (.csv) with the data as listed below.

Native Statistics

When exporting a STEP file, report what data importing systems should expect to find. For numeric statistics, enter the respective value or 'na' if not supported. For other statistics, select either 'full support' (i.e. test case and Rec. Pracs. definitions are fulfilled), 'limited support' (meaning the implementation does not meet all criteria and issues may be expected on import), or 'na' if not supported.

Target Statistics

When importing a STEP file, report the results found after processing the file as described in the table below.

Scope-specific Statistics:

The following table lists the key parameters define in the test model. In order for the test to be considered a success, the following information must be preserved during the exchange:

- Name of the Rosette
- Name of the associated Guide Curve
- Orientation Angle

The statistics gathered in CAESAR will record whether all, some, or none of there were transferred successfully.

Sequence	Ply	Core Material ID	Orientation	Rosette	Guide Curve
Sequence.1	Ply 1	10745	0°	Rosette A	Guide_Curve_90_Rosette A
Sequence.2	Ply 2	10745	45°	Rosette A	Guide_Curve_90_Rosette A
Sequence.3	Ply 3	10745	-45°	Rosette A	Guide_Curve_90_Rosette A
Sequence.4	Ply 4	10745	90°	Rosette A	Guide_Curve_90_Rosette A
Sequence.5	Ply 5	10745	0° or 90°	Rosette A	Guide_Curve_90_Rosette A
Sequence.6	Ply 6	10745	+45° or -45°	Rosette A	Guide_Curve_90_Rosette A

Data Sheet Columns

column name	description
model	The name of the test model, here 'CO4'
system_n	The system code of the CAD system creating the STEP file
system_t	The system code of the CAD system importing the STEP file. For native stats, select 'stp'
rosette_names	all/partial/none - whether all, some, or none of the Rosette names for Ply X of Sequence Y have been transferred correctly per the test case definition.
rosette_curve_names	all/partial/none - whether all, some, or none of the names of the curves related to the Rosettes have been transferred correctly per the test case definition.
orientation_values	all/partial/none - whether all, some, or none of the orientation values for Ply X of Sequence Y have been transferred correctly per the test case definition.
date	The date when the statistics were last updated (will be filled in automatically)
issues	A short statement on issues with the file

2.8 Test Case IO1: Alternative Part Shapes

All information about this test case can also be viewed in CAESAR on its Information page.

2.8.1 Motivation

Several scenarios have been discussed that require storing more than one shape for a particular part. In Round 49J, the use case in focus is storing the precise B-Rep shape and the equivalent tessellated shape of the same part version and view in one STEP file.

2.8.2 Approach

The approach to be used is described in the draft Recommended Practices for Alternative Shapes, version 0.2, dated 23 November 2021. It can be found in the member area of the CAx-IF homepages under “Information on Round 49J of Testing”.

This test case relates to section 5 of this document, “Alternative Representations for Equivalent Part Shapes”.

2.8.3 Testing Instructions

The model used for this test is the traditional “IO1” (“flange”) test model.

For those vendors who do not have the IO1 model:

- Modeling instructions can be found in the Round2J Test Suite document (v2.0; August 31, 1999), which can be found on the public CAx-IF web sites under “CAx Interoperability Forum > Implementor Group > CAx Test Rounds”.
- STEP files for IO1 are available in the CAx-IF member area, within the STEP File Vaults for Rounds 38J, 37J, 22J, 18J, and 9J.

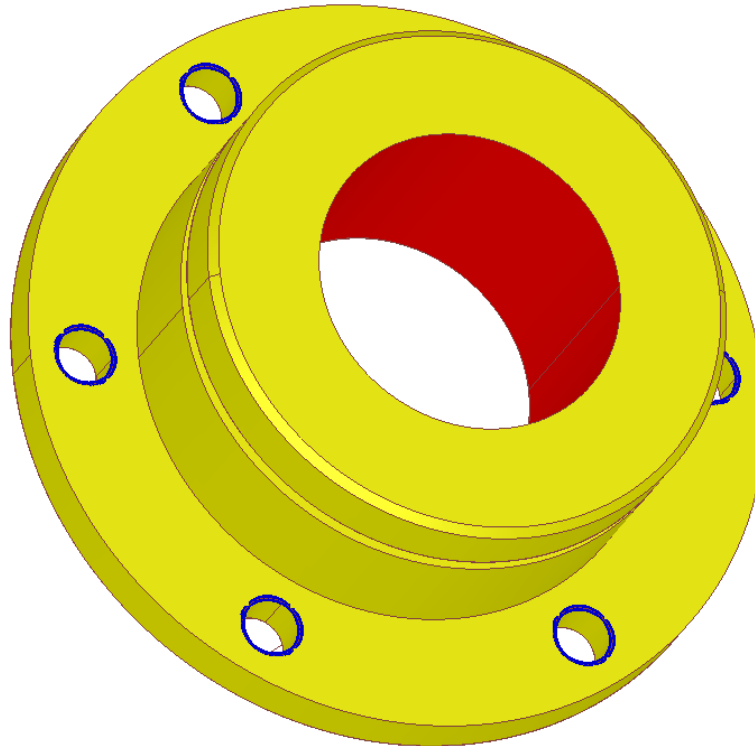

Figure 9: Illustration (shape & colors) of IO1

Each STEP file submitted for the IO1 test case shall contain:

Alternative Shapes

- The part shape as precise advanced B-Rep
- The equivalent Tessellated Shape, following the structure given in Figure 2 or 3 of the draft Rec. Practices.

Validation Properties

- Include the applicable Geometric and Tessellated Validation Properties.

2.8.4 Statistics

For each STEP file exported or imported for the IO1 test case, vendors must submit the corresponding statistics. To do so, go to the [IO1 Data Sheet], and either fill in the web form, or upload a comma-delimited file (.csv) with the data as listed below.

Native Statistics

When exporting a STEP file, report what data importing systems should expect to find. For numeric statistics, enter the respective value or 'na' if not supported. For other statistics, select 'full support' (i.e. test case and Rec. Pracs. definitions are fulfilled), 'limited support' (meaning the implementation does not meet all criteria and issues may be expected on import), or 'na' if not supported.

Target Statistics

When importing a file, report the results found after processing the file as described below:

Data Sheet Columns

column name	description
model	The name of the test model, here: 'IO1'
system_n	The system code of the CAD system creating the STEP file
system_t	The system code of the CAD system importing the STEP file. For native stats, enter 'stp'
unit	The unit the model is designed in
volume	Total volume of all solids
area	Total surface area of all solids
cx	Centroid of the model
cy	
cz	
facets	The number of facets in the Tessellated model
alt_shapes	all/partial/none - whether the alternative part shapes in the model were processed correctly
date	The date when the statistics were last updated (will be filled in automatically)
issues	A short statement on issues with the file

Annex A NIST Model Translation Configuration Considerations

Based on data translation issues identified in the NIST Phase 2 project (requiring multiple dataset submission iterations to resolve), the following translator configuration considerations have been derived for the PMI test case in Round 49J:

- Include annotations, coordinate systems, model properties, and PMI views
- Include supplemental geometry (non-solid surfaces, curves, points)
- Preserve annotation associations with both product and supplemental geometry
- Preserve annotation semantic PMI properties
 - Clearly point out if these are intentionally not translated
- Preserve annotation text
 - Creo should be configured to display dimension tolerances (tol_display on)
 - Do not drop leading zeros or add trailing zeros
- Preserve annotation units
 - CTC 01, 02, and 04 are defined in millimeters
 - CTC 03 and 05 are defined in inches
 - FTC 06 through 09 models are defined in inches
 - FTC 10 and 11 models are defined in millimeters
- Preserve display names of annotations and coordinate systems
 - Point out if you use NX 9 or newer since this will change some of the annotation names (see Figure 10 below)
- Preserve display colors of product geometry, supplemental geometry, and annotations
- Preserve view-specific visibility of annotations, coordinate systems, and supplemental geometry:
 - In the ZIP files with the test case specifications (see links in section 2.1.3), there is a PDF named "*nist_[ctc/ftc]_suppl_elem_visibility.pdf*" which gives a detailed definition of which elements shall be visible in which view, and which not.
 - Note that for each test case, there is a second PDF document included in the ZIP files, named "*..._elem_ids.pdf*" which contains the element ids for unambiguous identification of all PMI.
- Preserve view frustum (orientation and zoom level) definition:
 - JT model views should be defined so they are listed in the "Model Views" menu of JT2Go and work properly when selected
- Do not export extraneous information
 - Only CATIA Captures (not Views) should be exported to STEP Saved Views
 - Creo sketch dimensions should only be included when visible in a Combined View

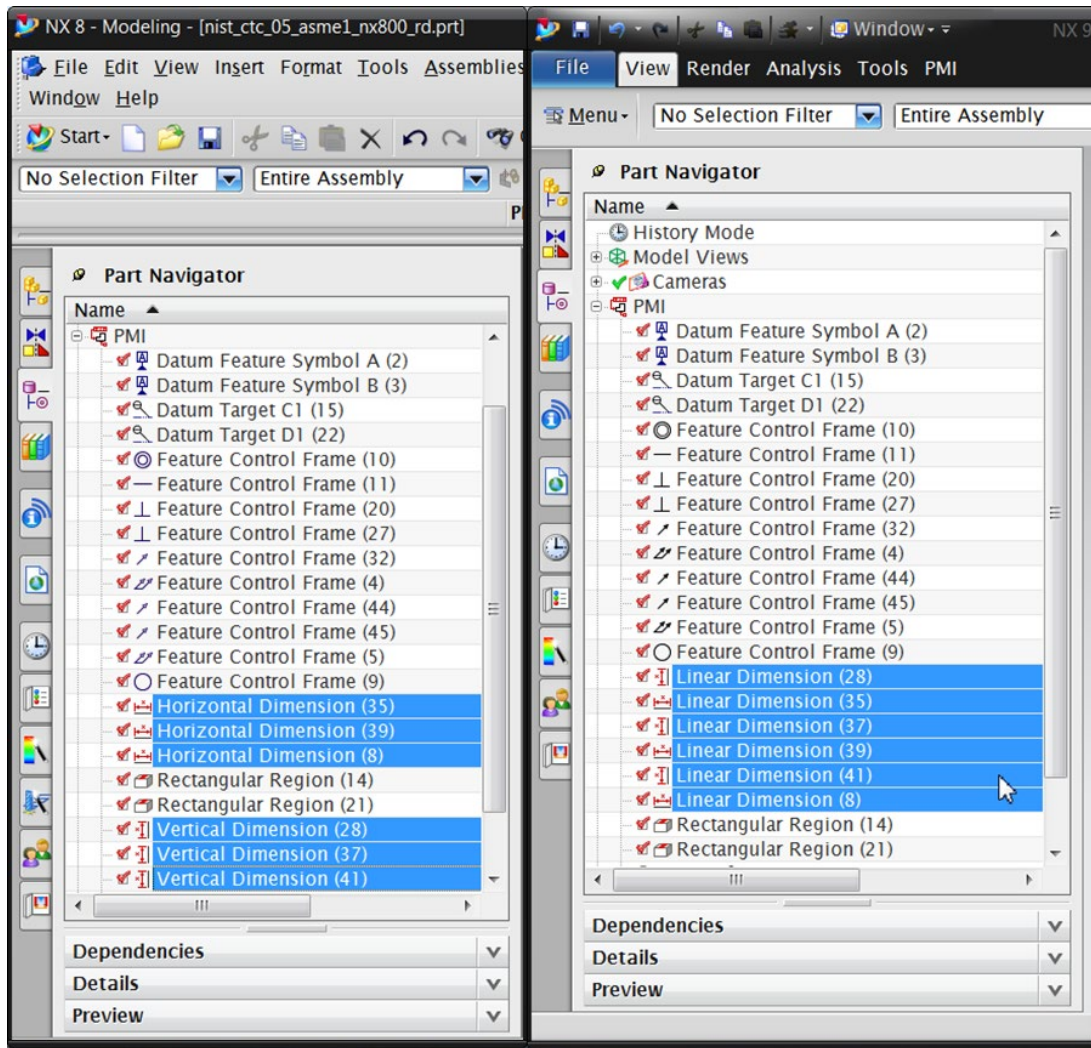

Figure 10: NX 8 vs. NX 9 Dimension Display Names

Annex B NIST Model Definitions

This section provides an overview of the test models used for testing of PMI capabilities in Round 49J. All of these models have been developed in the course of NIST’s “MBE PMI Validation and Conformance Testing Project”. Information on this project and related activities can be found on internet at <https://go.usa.gov/mGVm>

The full suite of models consists of two data sets:

First, the so-called Complex Text Cases (CTC). These are the models with indices 01-05. They contain a collection of basic PMI constructs. Download the definitions from:

https://s3.amazonaws.com/nist-el/mfg_digitalthread/NIST_CTC_Definitions_Dec_2016.zip

Second, the so-called Fully-toleranced Test Cases (FTC). These are the models with indices 06-11. They are fully defined models, providing all information required to actually manufacture and inspect the models. Download the definitions from:

https://s3.amazonaws.com/nist-el/mfg_digitalthread/NIST_FTC_Definitions_Dec_2016.zip

In order to reduce the workload for the participating vendors, not all eleven models shall be tested in Round 49J. The following five models have been chosen:

- PMI: FTCs 6, 7, 8, 9, 10, 11

This selection still covers a wide range of PMI elements, while reducing the number of exchanged to be done for each interface vendor. The models are indicated with a label below.

The illustrations below show the first page of the PDF document for each test model.

NIST PMI Test Models - 2012

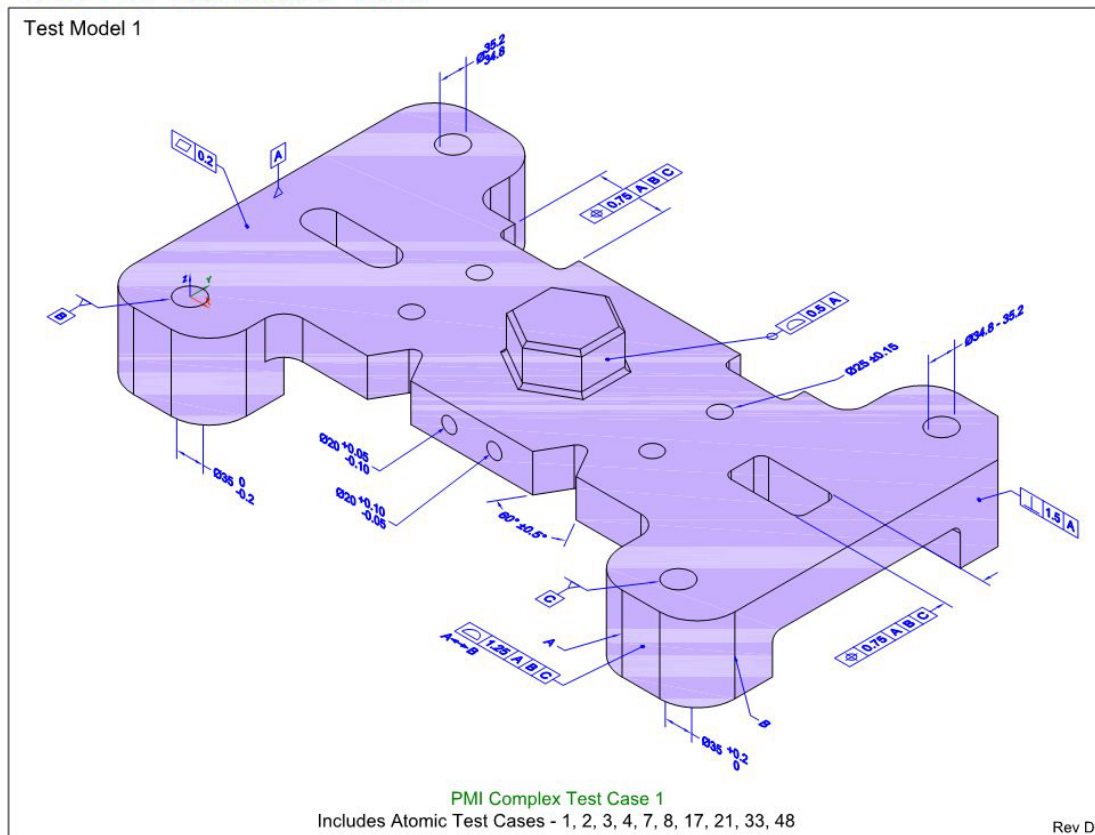

NIST PMI Test Models - 2012

Test Model 2

NOTES (UNLESS OTHERWISE SPECIFIED):

- OBTAIN DIMENSIONS FOR ALL UNDIMENSIONED FEATURES FROM THE MODEL. ALL DIMENSIONS OBTAINED FROM THE MODEL ARE BASIC UNLESS OTHERWISE SPECIFIED.
- ASME Y14.41-2003 APPLIES TO DATASET.
- ASME Y14.5M-1994 APPLIES TO DIMENSIONING AND TOLERANCING.

These notes shall be placed on a static annotation plane (the plane does not rotate with the model).

The intent of ATC50 is to test systems' support for static annotation planes.

Including a feature control frame in a general note will be a test case in the next round of testing.

PMI Complex Test Case 2 - View 1 (of 3)
 Includes Atomic Test Cases - 28, 29, 43, 47, 50

Rev C

nist_ctc_02_asme1_rc

NIST PMI Test Models - 2012

Test Model 3

Datum Feature F not referenced - justifies placing MCS at center of large hole on flange

PMI Complex Test Case 3
 Includes Atomic Test Cases - 6, 13, 14, 20, 27, 32, 36, 39, 45, 46

Rev C

nist_ctc_03_asme1_rc

NIST PMI Test Models - 2012

Test Model 4

This tolerance applies to the top surfaces above datum features G and H. The string "2 SURFACES" does not clarify which surfaces. Associativity will.

Tolerances and Dimensions:

- ± 0.25 (2 SURFACES)
- ± 0.2 (2 SURFACES)
- ± 0.10
- 0.05 A B C
- 0.5 A B C
- 0.625 A-B
- 0.65 A
- 0.002
- 0.05 A-B
- 0.005 (D)
- 0.008
- 0.005
- 0.002
- 0.002 A-B
- 0.002 A-B
- 0.002 C
- 0.002 D
- 0.002 E
- 0.002 F
- 0.002 G
- 0.002 H
- 0.002 I
- 0.002 J
- 0.002 K
- 0.002 L
- 0.002 M
- 0.002 N
- 0.002 O
- 0.002 P
- 0.002 Q
- 0.002 R
- 0.002 S
- 0.002 T
- 0.002 U
- 0.002 V
- 0.002 W
- 0.002 X
- 0.002 Y
- 0.002 Z
- 0.002 AA
- 0.002 AB
- 0.002 AC
- 0.002 AD
- 0.002 AE
- 0.002 AF
- 0.002 AG
- 0.002 AH
- 0.002 AI
- 0.002 AJ
- 0.002 AK
- 0.002 AL
- 0.002 AM
- 0.002 AN
- 0.002 AO
- 0.002 AP
- 0.002 AQ
- 0.002 AR
- 0.002 AS
- 0.002 AT
- 0.002 AU
- 0.002 AV
- 0.002 AW
- 0.002 AX
- 0.002 AY
- 0.002 AZ

PMI Complex Test Case 4
Includes Atomic Test Cases - 5, 9, 10, 12, 15, 16, 22, 30, 40, 49

Rev D

NIST PMI Test Models - 2012

Test Model 5

Notes
Datum feature B and
Datum target D1 defined
in View 2 (of 2).

Tolerances and Dimensions:

- 0.025 A-B
- 0.002
- 0.005 A-B
- 0.005 (D)
- 0.008
- 0.005
- 0.002
- 0.002 A-B
- 0.002 A-B
- 0.002 C
- 0.002 D
- 0.002 E
- 0.002 F
- 0.002 G
- 0.002 H
- 0.002 I
- 0.002 J
- 0.002 K
- 0.002 L
- 0.002 M
- 0.002 N
- 0.002 O
- 0.002 P
- 0.002 Q
- 0.002 R
- 0.002 S
- 0.002 T
- 0.002 U
- 0.002 V
- 0.002 W
- 0.002 X
- 0.002 Y
- 0.002 Z
- 0.002 AA
- 0.002 AB
- 0.002 AC
- 0.002 AD
- 0.002 AE
- 0.002 AF
- 0.002 AG
- 0.002 AH
- 0.002 AI
- 0.002 AJ
- 0.002 AK
- 0.002 AL
- 0.002 AM
- 0.002 AN
- 0.002 AO
- 0.002 AP
- 0.002 AQ
- 0.002 AR
- 0.002 AS
- 0.002 AT
- 0.002 AU
- 0.002 AV
- 0.002 AW
- 0.002 AX
- 0.002 AY
- 0.002 AZ

PMI Complex Test Case 5 - View 1 (of 2)
Includes Atomic Test Cases - 11, 18, 19, 23, 24, 37, 42, 44

Rev D

NIST PMI Test Models - 2014

NOTES (UNLESS OTHERWISE SPECIFIED):

- CAD MODEL _____ REV. ___ IS REQUIRED TO COMPLETE PRODUCT DEFINITION.
- DIRECTLY-TOLERANCED DIMENSIONS AND BASIC DIMENSIONS DEFINED ON THE DRAWING TAKE PRECEDENCE OVER DIMENSIONAL DATA DEFINED BY THE MODEL. OBTAIN ALL OTHER DIMENSIONAL DATA FROM THE MODEL. THE MODEL REPRESENTS BASIC DIMENSIONAL DATA UNLESS OTHERWISE SPECIFIED.
- APPLICABLE STANDARDS:
 ASME Y14.41-2003 APPLIES TO DATASET.
 ASME Y14.5M-1994 APPLIES TO DIMENSIONING AND TOLERANCING.
- $\text{[Symbol: Flatness]} .05 \text{ [A] [B] [C]}$ APPLIES TO ALL UNTOLERANCED SURFACES.
- UNITS: INCHES

Feature and Specification Index
R49J

PMI Fully-Toleranced Test Case 6 - View A
 Includes Atomic Test Cases - 52, 53, 72, 87, 88, 89

Rev D nist_ftc_06_asme1_rd

NIST PMI Test Models - 2014

NOTES (UNLESS OTHERWISE SPECIFIED):

- CAD MODEL _____ REV. ___ IS REQUIRED TO COMPLETE PRODUCT DEFINITION.
- DIRECTLY-TOLERANCED DIMENSIONS AND BASIC DIMENSIONS DEFINED ON THE DRAWING TAKE PRECEDENCE OVER DIMENSIONAL DATA DEFINED BY THE MODEL. OBTAIN ALL OTHER DIMENSIONAL DATA FROM THE MODEL. THE MODEL REPRESENTS BASIC DIMENSIONAL DATA UNLESS OTHERWISE SPECIFIED.
- APPLICABLE STANDARDS:
 ASME Y14.41-2003 APPLIES TO DATASET.
 ASME Y14.5M-1994 APPLIES TO DIMENSIONING AND TOLERANCING.
- $\text{[Symbol: Flatness]} .06 \text{ [A] [B] [C]}$ APPLIES TO ALL UNTOLERANCED SURFACES.
- FEATURES IDENTIFIED AS STATISTICALLY TOLERANCED (ST) SHALL BE PRODUCED WITH STATISTICAL PROCESS CONTROLS OR TO THE MORE RESTRICTIVE ARITHMETIC LIMITS SPECIFIED. DETAILED PROCESS PLAN NEEDED TO COMPLETELY DEFINE STATISTICAL PARAMETERS AND REQUIREMENTS.
- UNITS: INCHES

Feature and Specification Index
R49J

PMI Fully-Toleranced Test Case 7 - View A
 Includes Atomic Test Cases - 84, 85

Rev D nist_ftc_07_asme1_rd

NIST PMI Test Models - 2014

NOTES (UNLESS OTHERWISE SPECIFIED):

- CAD MODEL _____ REV. ____ IS REQUIRED TO COMPLETE PRODUCT DEFINITION.
- DIRECTLY-TOLERANCED DIMENSIONS AND BASIC DIMENSIONS DEFINED ON THE DRAWING TAKE PRECEDENCE OVER DIMENSIONAL DATA DEFINED BY THE MODEL. OBTAIN ALL OTHER DIMENSIONAL DATA FROM THE MODEL. THE MODEL REPRESENTS BASIC DIMENSIONAL DATA UNLESS OTHERWISE SPECIFIED.
- APPLICABLE STANDARDS:
 ASME Y14.41-2003 APPLIES TO DATASET.
 ASME Y14.5M-1994 APPLIES TO DIMENSIONING AND TOLERANCING.
- $\square .06 \square A \square B \square C$ APPLIES TO ALL UNTOLERANCED SURFACES.
- DIMENSIONING AND TOLERANCING APPLY WITH PART RESTRAINED AS FOLLOWS, EXCEPT AS INDICATED.
 PLACE DATUM FEATURE A AGAINST DATUM FEATURE SIMULATOR A.
 ENGAGE DATUM FEATURES B AND C WITH DATUM FEATURE SIMULATORS B AND C RESPECTIVELY.
 APPLY LOAD TO PART TO RESTRAIN DATUM FEATURE A AGAINST ITS SIMULATOR.
 DETAILED INSPECTION PLAN NEEDED TO COMPLETELY DEFINE RESTRAINT.
- UNITS: INCHES

Feature and Specification Index
R49J

PMI Fully-Toleranced Test Case 8 - View A
 Includes Atomic Test Cases - 66, 90

Rev C

nist_ftc_08_asme1_rc

NIST PMI Test Models - 2014

NOTES (UNLESS OTHERWISE SPECIFIED):

- CAD MODEL _____ REV. ____ IS REQUIRED TO COMPLETE PRODUCT DEFINITION.
- DIRECTLY-TOLERANCED DIMENSIONS AND BASIC DIMENSIONS DEFINED ON THE DRAWING TAKE PRECEDENCE OVER DIMENSIONAL DATA DEFINED BY THE MODEL. OBTAIN ALL OTHER DIMENSIONAL DATA FROM THE MODEL. THE MODEL REPRESENTS BASIC DIMENSIONAL DATA UNLESS OTHERWISE SPECIFIED.
- APPLICABLE STANDARDS:
 ASME Y14.41-2003 APPLIES TO DATASET.
 ASME Y14.5M-1994 APPLIES TO DIMENSIONING AND TOLERANCING.
- DIMENSION AND TOLERANCE VALUES SHOWN IN SQUARE BRACKETS [XXX] ARE MILLIMETERS.
- MATERIAL: (.1195 THICK) 11 GA 304 SST SHT, ASTM A240.
- UNITS: INCHES

Feature and Specification Index
R49J

PMI Fully-Toleranced Test Case 9 - View A
 Includes Atomic Test Cases - 59, 61

Rev D

nist_ftc_09_asme1_rd

NIST PMI Test Models - 2014

R49J

NOTES (UNLESS OTHERWISE SPECIFIED):

1. CAD MODEL _____ REV. ___ IS REQUIRED TO COMPLETE PRODUCT DEFINITION.
2. DIRECTLY-TOLERANCED DIMENSIONS AND BASIC DIMENSIONS DEFINED ON THE DRAWING TAKE PRECEDENCE OVER DIMENSIONAL DATA DEFINED BY THE MODEL. OBTAIN ALL OTHER DIMENSIONAL DATA FROM THE MODEL. THE MODEL REPRESENTS BASIC DIMENSIONAL DATA UNLESS OTHERWISE SPECIFIED.
3. APPLICABLE STANDARDS:
 ASME Y14.41-2003 APPLIES TO DATASET AND MOVABLE DATUM TARGETS.

 ASME Y14.5M-1994 APPLIES TO DIMENSIONING AND TOLERANCING.
4. FULL DIAMETER OF EACH INDICATED HOLE MUST INTERSECT WITH THE CROSS-DRILLED HOLE AT ITS BOTTOM. INDICATED HOLES MUST NOT CONTACT FAR SIDE OF CROSS-DRILLED HOLES.
5. $\text{1.5} \text{A} \text{B} \text{C}$ APPLIES TO ALL UNTOLERANCED SURFACES.
6. UNITS: MILLIMETERS

PMI Fully-Toleranced Test Case 10 - View A
Includes Atomic Test Cases - N/A

Rev B nist_fic_10_asme1_rb

NIST PMI Test Models - 2014

R49J

NOTES (UNLESS OTHERWISE SPECIFIED):

1. CAD MODEL _____ REV. ___ IS REQUIRED TO COMPLETE PRODUCT DEFINITION.
2. DIRECTLY-TOLERANCED DIMENSIONS AND BASIC DIMENSIONS DEFINED ON THE DRAWING TAKE PRECEDENCE OVER DIMENSIONAL DATA DEFINED BY THE MODEL. OBTAIN ALL OTHER DIMENSIONAL DATA FROM THE MODEL. THE MODEL REPRESENTS BASIC DIMENSIONAL DATA UNLESS OTHERWISE SPECIFIED.
3. APPLICABLE STANDARDS:
 ASME Y14.41-2003 APPLIES TO DATASET.

 ASME Y14.5M-1994 APPLIES TO DIMENSIONING AND TOLERANCING.
4. NON-RIGID PART. DIRECTLY-TOLERANCED DIMENSIONS AND TOLERANCES APPLY IN FREE STATE.
5. UNITS: MILLIMETERS

PMI Fully-Toleranced Test Case 11 - View A
Includes Atomic Test Cases - 55, 100

Rev B nist_fic_11_asme1_rb