



**Test Suite for the  
CAX Interoperability Forum  
Round 50J**

March – September 2022

***Release 1.1***

20 July 2022

**Contacts**

Jochen Boy  
PROSTEP AG  
[jochen.boy@prostep.com](mailto:jochen.boy@prostep.com)

Jacques Heinisch  
AFNeT Services  
[jacques.heinisch@afnet-services.fr](mailto:jacques.heinisch@afnet-services.fr)

Phil Rosché  
ACCR, LLC.  
[phil.rosche@accr-llc.com](mailto:phil.rosche@accr-llc.com)

Robert Lipman  
NIST  
[robert.lipman@nist.gov](mailto:robert.lipman@nist.gov)

## Table of Contents

<b>1</b>	<b>Introduction.....</b>	<b>3</b>
1.1	Functionality tested in this round .....	4
1.2	General testing instructions for this round.....	5
1.3	Testing Schedule.....	5
1.4	Copyrights on Test Cases .....	5
<b>2</b>	<b>Synthetic Test Case Specifications .....</b>	<b>6</b>
2.1	Test Case PMI: Semantic PMI Representation & Graphic PMI Presentation .....	6
2.2	APP: Assembly PMI Presentation.....	12
2.3	Test Case KM2: Kinematics.....	14
2.4	Test Case UD4: User Defined Parameters .....	18
2.5	Test Case AS3: AP242 Edition 2 Minor Revision Domain Model XML.....	22
2.6	Test Case CO4: Composite Part with Multiple Rosette .....	26
2.7	Test Case CO5: Composite Part with Rosette Guided by a Curve 90° .....	29
2.8	Test Case ASR: Alternative Shape Representation with PMI.....	32
<b>Annex A</b>	<b>NIST Model Translation Configuration Considerations .....</b>	<b>35</b>
<b>Annex B</b>	<b>NIST Model Definitions.....</b>	<b>37</b>

## List of Figures

Figure 1:	CAx-IF Round 50J Schedule .....	5
Figure 2:	Illustration of the "Vise" test model; Saved View "MBD_05".....	13
Figure 3:	Illustration of the KM2 test model with indicated kinematic pairs.....	16
Figure 4:	Overview on User-Defined Parameters and Properties defined in the test model ..	19
Figure 5:	Overview on the Properties defined in the NX model for UD4.....	20
Figure 6:	Illustration of the Torque Converter model.....	23
Figure 7:	Torque Converter structure and indication of included attributes .....	24
Figure 8:	Illustration of the CO4 Test Case and Laminate Table.....	27
Figure 9:	Illustration of the CO5 Test Case.....	30
Figure 10:	Illustration of the CTC-5 model used for the ASR test case .....	33
Figure 11:	NX 8 vs. NX 9 Dimension Display Names .....	36

## Document History

Release	Date	Change
1.0	2022-06-28	Initial Release
1.1	2022-07-20	Added note on updated CATIA models to PMI test case Added NX model to UD4 test case

## 1 Introduction

The CAx Interoperability Forum (CAx-IF) is part of the Model-Based Interoperability Forum (MBx-IF), which is a joint effort between AFNeT, PDES, Inc. and prostep ivip. An interoperability forum is a logical collection of a user group and an implementer group, focused on specific capabilities of a named standard, in this case ISO 10303 STEP.

- The **User Group** is comprised of industry representatives, all members of at least one of the Interoperability Forum hosting organizations. The group will define and prioritize use cases, derive requirements and related validation properties as well as document user best practices.
- The **Implementor Group** is a group of software vendors, 3<sup>rd</sup> party integrators, and independent implementors, all members of at least one of the Interoperability Forum hosting organizations, that define recommended practices based on the prioritized use cases provided by the user group and validate them in test rounds.

The objectives of the CAx-IF concentrate primarily on testing the interoperability and compliance of STEP processors based on AP242 Editions 1, 2, and 3, and include documenting and prioritizing use cases, requirements and best practices to ensure completeness and consistency of the STEP standard and its implementations, implementing new functionalities based on users' requirements while ensuring these do not adversely affect existing implementations, avoiding roadblocks by establishing agreed-upon approaches, and increasing user confidence in STEP by providing interoperable commercial software products.

The CAx-IF's Implementor Group performs two test rounds per year for each domain and presents summary results to the user community. Furthermore, Recommended Practices are developed, and issues are reported to the standards development community.

The test rounds in general combine testing of synthetic and production models. Production models will in most cases be provided by the user companies of the organizations AFNeT, PDES, Inc., and prostep ivip Association. When production models are not available from the user companies, "production-like" models will be solicited from the various CAx-IF participants.

This test suite includes synthetic models for testing the following capabilities: Product Manufacturing Information (PMI), both as Graphic Presentation and as Semantic Representation, 3D Tessellated Geometry, Kinematics, Composite Materials, Assembly Structure with External References as well as Kinematic Mechanism definitions in AP242 Domain Model XML format, and Persistent Entity IDs.

## 1.1 *Functionality tested in this round*

Functionality tested in this round relates to:

- **Product Manufacturing Information (PMI)** describes the capability to embed information about dimensions, tolerances and other parameters which are necessary input for the manufacturing and measuring of the part from the 3D model. In this round, the focus will be on the two approaches for the transfer of PMI in the 3D model:
  - “Tessellated Presentation” refers to breaking down each annotation into tessellated elements as supported by AP242 and exchanging them as geometry. This preserves the exact shape of the annotation but is human readable only.
  - “Semantic Representation” refers to the intelligent transfer of PMI data in an associative and reusable way. This scenario aims towards driving downstream usage and later modifications of the model. The data is machine-readable, but not necessarily visible in the 3D model. The test also includes additional presentation data, which can be linked to the corresponding PMI representation.
  - “Assembly-level PMI” applies the concept above to assemblies, where PMI elements are defined between different parts, or part instances. Concepts such as Saved Views and Cross-Highlighting shall work in the same way.
- **AP242 Domain Model XML** is an implementation format introduced with AP242, and the designated process format for many applications in the aerospace and automotive industries. It will be used in combination with geometry formats matching the respective requirement. In the CAX-IF, the geometry files will be in STEP Part 21 format. The XML files contain the assembly structure and part master information. The tests, which are conducted jointly with the PDM-IF, primarily aim at improving CAX-PDM interoperability by ensuring that the different types of systems correctly cope with the different levels of information.
- **Composite Materials** are made by layering various plies of material on top of each other. They can be defined in an implicit-precise way, by giving the laminate tables, ply boundaries, orientation, materials, and laminated cores; or in an explicit-tessellated way by calculating the resulting 3D Tessellated Solid. Both representations can be linked to each other.
- **Kinematics** is a capability in AP242 that allows describing the motion of parts over time and in relation to each other. This includes the definition of mechanisms with joints and constraints, defining the kinematic relationships between the parts, as well as motions, which are defined by capturing the positions of the moving parts at discrete points in time. To cover Aerospace as well as Automotive use cases, and to increase the range of participating systems, this capability is being tested jointly with the JT-IF.
- **Persistent Entity IDs** enable the ability to track a product’s model information during design iteration, and from there through to manufacturing and quality analysis. This will allow downstream systems to update their representations of the design model and update their manufacturing and metrology planning to reflect changes in the design.
- **User Defined Parameters** at the part level as well as at the geometry level are used to convey data that drives certain aspects of a model, e.g., geometric features, or engineering notes and requirements that manufacturing must comply with. This may also include custom-defined properties. A target application shall be able to pick up on these and make appropriate decisions for downstream processes.
- **Alternative Shapes Representations** is a capability that allows for storing several different representations of the same part in a single file. This approach can be applied at various levels in the model structure, supporting a range of use cases. In Round 50J, the focus is on adding PMI to the precise B-Rep shape and tessellated shape for the same part while preserving the correct associations between PMI and part shape.

## 1.2 General testing instructions for this round

The general procedures for communication of models and statistics are outlined in a separate document, entitled 'General Testing Instructions'. The document can be retrieved from the CAx Interoperability Forum web sites. The latest version is v1.13, dated September 29, 2017.

## 1.3 Testing Schedule

The following schedule has been agreed upon for Round 50J:

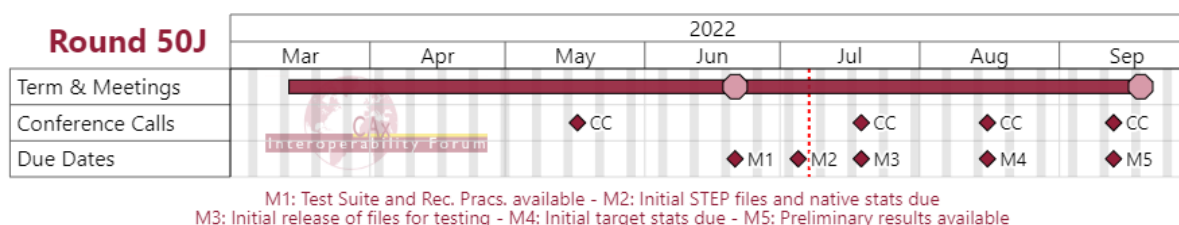

Date	Action
18 May 2022 (Wed)	Round 49J Follow-up / Round 50J Preparation Call
22 Jun 2022 (Wed)	CAx-IF Round 50J Kick-Off Meeting / Test Suite and Rec. Pracs. available
6 Jul 2022 (Wed)	Initial STEP files and native stats due
20 Jul 2022 (Wed)	1 <sup>st</sup> CAx-IF Round 50J Conference Call / Initial release of files for testing
17 Aug 2022 (Wed)	2 <sup>nd</sup> CAx-IF Round 50J Conference Call / Initial target stats due
14 Sep 2022 (Wed)	3 <sup>rd</sup> CAx-IF Round 50J Conference Call / Preliminary results available
19 Sep 2022 (Mon) - 21 Sep 2022 (Wed)	CAx-IF Round 50J Review Meeting in Charleston, SC, USA

Figure 1: CAx-IF Round 50J Schedule

The test round review meeting in March will once again be held fully online, due to the ongoing pandemic and related travel restrictions.

## 1.4 Copyrights on Test Cases

### 1.4.1 CAx-IF

None of the production test cases which were provided by the AFNeT, PDES, Inc. and prostep ivip member companies may be publicly released for any purpose. The test cases can be freely distributed among the CAx-IF members and can be used for any purposes that are related to CAx-IF testing (i.e., testing, documentation of testing efforts, etc.), if a reference to the originating company is made.

The test cases must not be used for any purposes other than CAx-IF testing or outside of AFNeT, PDES, Inc. and prostep ivip. Test cases provided by the LOTAR project for testing of specific capabilities are applicable to the same restrictions and may not be used outside LOTAR or the CAx-IF.

## 1.4.2 NIST

The test cases developed at the National Institute of Standards and Technology (NIST) are not subject to copyright protection and are in the public domain. NIST assumes no responsibility for the components of the test system for use by other parties and makes no guarantees, expressed or implied, about their quality, reliability, or any other characteristic. The use of the CAD systems to create the Test Models does not imply a recommendation or endorsement by NIST.

For more details, read the disclaimer at <https://go.usa.gov/xuh9n>

## 2 Synthetic Test Case Specifications

### 2.1 Test Case PMI: Semantic PMI Representation & Graphic PMI Presentation

All information about this test case can also be viewed in CAESAR on its Information page.

#### 2.1.1 Motivation

Product Manufacturing Information (PMI) is required for numerous business use cases in the context of STEP data exchange. Among others, it is a prerequisite for long-term data archiving. In addition, PMI can be used to drive downstream applications such as coordinate measuring and manufacturing.

Semantic PMI Representation relates to the capability to store PMI data in the STEP file in a computer-interpretable way, so that it can be used for model redesign or downstream applications. Though the definition of the data is complete, it is by itself not visible in the 3D model.

In addition to use cases that require a fully defined, precise, semantic definition of the part geometry and associated PMI, there are also scenarios where the presentation of the data – geometric elements and annotations – for visual consumption are the primary goal. In such cases, a simplified and optimized version of the model is sufficient. The tessellated geometry model included in AP242 provides an efficient mechanism to support this.

A wide variety of test models is available from NIST as well as prostep ivip, each containing a different selection of PMI elements. Each model is typically concentrated on specific subsets of PMI data.

#### 2.1.2 User Stories

This test case supports the following User Stories provided by the CAX-IF UG on Redmine:

ID	Title
<a href="#">#49</a>	Saved views Validation Properties
<a href="#">#124</a>	Default saved view
<a href="#">#184</a>	Annotation placeholder

#### 2.1.3 Approach

The approach to be used is described in the latest version (at least v4.0.10, dated 7 March 2022) of the “Recommended Practices for Representation and Presentation of PMI (AP242)”, which can be found in the CAX-IF member area under “Information on Round49J of Testing”.

Within the PMI domain, the following functionalities are in scope of Round 50J:

- Semantic PMI Representation
- Tessellated PMI Presentation
- Correct implementation and definition of the Saved Views (view layout and contents)

- Linking of PMI Representation to Presentation
- Transfer of editable PMI text as User Defined Attributes
- PMI Validation Properties (Representation & Presentation)
- Presentation Placeholder (including Placeholder Leader Lines if supported)

The AP242 schema to be used is the **AP242 Edition 3** schema, which is available on the CAX-IF homepages under "Public Testing Information". This schema provides full support of the latest changes and additions in the Recommended Practices, in particular, the Presentation Placeholder. The AP242 Ed.2 schema can be used if Ed.3 is not yet supported, respecting the scope limitations.

**Pre-checking of files with SFA:** All vendors generating STEP files for the PMI test case shall run them through the latest version of NIST's STEP File Analyzer and Viewer (SFA; currently version 4.76). Use the Syntax Checker in SFA to check for basic syntax errors such as missing and malformed entity instances. Files with such errors will not be accepted for testing.

SFA can be downloaded for free at:

<https://www.nist.gov/services-resources/software/step-file-analyzer-and-viewer>

## 2.1.4 Testing Instructions

The tests will be performed based on a verified set of test models, each with set of well-defined PMI elements. In Round 50J, the models developed in the context of the "MBE PMI Validation and Conformance Testing" project will be used again, as they have been designed with emphasis on specific PMI capabilities.

### 2.1.4.1 NIST Test Model Overview

The NIST models are constantly updated to the latest CAD software releases by the respective system vendors, in order to improve the definition of the models using the latest CAD system capabilities.

The links to the test model definitions, the NIST web page for the MBE PMI Validation and Conformance Testing Project, and illustrations of the 11 test cases can be found at the end of this document in Annex B.

### 2.1.4.2 NIST Test Model Access

The updated native CAD files can be downloaded using the hyperlinks in the list below:

- [CATIA V5-6R2019](#)
- [Creo 4](#)
- [NX1980](#)
- [Inventor 2021](#)

**Note** that for the NIST CATIA models, there are updates for FTC 6, 10, and 11 in V5-6R2021. This is in addition to all of the CTC and FTC models in V5-6R2019. The updated FTC models should be used for testing if possible.

Even though many updates have already been made by the respective system vendors, a number of verification issues remain to be solved. Should new native models with further updates become available during the test round, they will be distributed and announced accordingly.



### 2.1.4.3 NIST Test Model Selection

A subset of the NIST test cases has been selected for Round 50J:

- **FTC-6:** Datum targets (lines and curves), radius, more holes
- **FTC-7:** PMI validation properties, dimensions, position tolerances and surface profile tolerances
- **FTC-8:** Complex and stacked feature control frames, mix of tolerances and modifiers
- **FTC-9:** Perpendicularity on hole diameter (every vendor had a different solution)
- **FTC-10:** Datum features and Datum targets; mix of tolerances and modifiers
- **FTC-11:** Dimension average, roundness tolerance

**Note** that the only change in this list is the addition of FTC-11, which has not been formally tested before. To help with prioritization, a list with noteworthy issues has been provided by Bob Lipman and is available as an annex to the Round 48J Meeting Minutes in the CAX-IF member area.

**Note** that to keep the workload within reasonable bounds, PMI validation properties will be formally evaluated only on FTC-7.

**Note** that vendors are encouraged to submit STEP files for all 11 NIST test cases, for investigation by Bob Lipman. However, only STEP files for the five models listed above will be distributed for testing in Round 50J and their respective results evaluated on CAESAR.

### 2.1.5 Test Model Configuration

The following functionality shall be included in the test files provided for this round of testing, as far as it has been implemented by the CAX-IF participants and is described in the Recommended Practices:

- PMI Representation – the re-usable representation of PMI data should be included in all PMI models to the extent supported by the native system.
- PMI Tessellated Presentation – Many CAD systems require some minimal presentation information to be able to handle the PMI data in a model. Usually, both PMI representation and presentation data are included in the same file. Thus, some form of presentation information shall be included in the PMI test case as well.
- PMI Presentation Placeholder – This information enables a target system with PMI authoring capability to recreate the presentation of a PMI element based on its Semantic Representation data. It intends to provide a minimal set of presentation information to CAD systems, which require information such as the leader line attachment point on the part geometry to create the corresponding Semantic PMI Representation elements.
  - Implementation of this capability requires the AP242 Ed.3 MIM Longform EXPRESS Schema, provided in the CAX-IF member area under “Information on Round 48J of Testing”, as well as the corresponding excerpt from version 4.0.10 of the PMI Recommended Practices, which is available under “Information on Round 49J of Testing”.
- Definition of “Saved Views” – as far as supported, include the saved views defined in the models, which contain a subset of annotations in the file, and provide a pre-defined position of the model in the design space.
  - All models have multiple Saved Views defined. In the test case definition documents, each page of the PDF document represents one Saved View.
  - For each view, a screenshot showing the model layout (displayed elements, orientation, zoom) shall be provided.



**Note** that it is possible to attach several screenshots to one set of statistics in CAESAR. The name of the view shall be given as description for the screenshot.

- Saved Views shall correctly show (or hide) the part geometry, as well as the non-solid Supplemental Geometry contained in some of the models (see section 9.4.2 / Figure 95 in the PMI Rec. Practices v4.0.10). A document pointing out important supplemental geometry elements for the NIST test cases is available in the CAx-IF member area, under “Information on Round 42J of testing”.
- Editable PMI Text – Some information relevant for PMI is not encoded in semantic entities, but given as plain text, such as the title block information or additional text on feature control frames. In the context of semantic data exchange, this content needs to be editable in the target system. The approach to be used for this is based on the transfer of User Defined Attributes, and its application in the context of PMI is described in section 7.4 of the PMI Recommended Practices v4.0.10.
- Linking PMI Representation to Presentation – If a model contains PMI Representation information as well as Presentation data, the corresponding elements shall be linked together, so that a Representation element “knows” which annotation it is being presented in the model. The approach to create this link is described in section 7.3 of the PMI Rec. Pracs. (v4.0.10).
- Cross-highlighting of annotations and annotated shape – if supported, include in the STEP file the information necessary to maintain the association between graphic annotations and the annotated shape elements in a way, that after import, when highlighting an annotation, the shape elements annotated by it are highlighted too, and vice versa.
- Validation Properties – All participants providing STEP files for this test case are encouraged to include validation properties for PMI semantic representation and graphic presentation, as defined in the PMI Recommended Practices v4.0.10, sections 10.1 and 10.2 respectively.
  - **Note** that in Round 50J, PMI validation properties will be formally evaluated only on the FTC-7 test case.
- Presentation Placeholder – As extension of the scope in Round 50J, STEP files created for the PMI test case shall also include Presentation Placeholders per section 7.2 in the PMI Recommended Practices (v4.0.10), as far as supported by the translator.

Vendors are encouraged to also include definitions of the placeholder leader lines (section 7.2.4), though these are not mandatory for an initial implementation of the placeholder. Note that to implement placeholder leader lines, the draft AP242 Edition 3 MIM Longform EXPRESS schema is required, which is available in the CAx-IF member area under “Information on Round 48J of Testing”.

Also refer to Annex A for test model translation configuration considerations.

## 2.1.6 Statistics

For each STEP file exported or imported for the PMI test case, vendors must submit the corresponding statistics. To do so, go to the [PMI Data Sheet], and either fill in the web form, or upload a comma-delimited file (.csv) with the data as listed below.

### Native Statistics

When exporting a STEP file, report what data importing systems should expect to find. For numeric statistics, enter the respective value or 'na' if not supported. For other statistics, select either 'full support' (i.e., test case and Rec. Pracs. definitions are fulfilled), 'limited support' (meaning the implementation does not meet all criteria and issues may be expected on import), or 'na' if not supported.

### Target Statistics

When importing a STEP file, report the results after processing the file as described below.

### Screenshots

For each Saved View in the model, provide one screenshot, which illustrates the layout (displayed geometry and annotations, model orientation, and zoom factor). Give the name of the view as the description of the screenshot. Note that CASEAR allows the addition of multiple screenshots per dataset.

**Note** that in order to count the GD&T elements for the statistics, per agreement during the R22J Review Meeting, the actual STEP entity types (`datum`, `datum_target`...) shall be considered.

**Note** that based on the Round 35J results, a new count has been added for Composite Tolerances as defined in section 6.9.9. of the PMI Rec. Pracs. (v4.0.8).

**Note** that all statistics – native and target – shall be based on the Semantic PMI Representation data only, and not take any presentation into account.

**Note** that for evaluation, the spreadsheets generated by the STEP File Analyzer and Viewer will be amended with corresponding aggregations of relevant counts and charts.

### Data Sheet Columns

column name	description
<b>model</b>	The name of the test model, here 'pmi', with one of the following suffixed: 06, 07, 08, 09, 10, 11.
<b>system_n</b>	The system code of the CAD system creating the STEP file
<b>system_t</b>	The system code of the CAD system importing the STEP file. For native stats, select 'stp'
<b>scope</b>	A short designation for the contents of the model as defined in the Test Suite. This is for information only; there will be no results for this field.
<b>dimensions</b>	The number of dimensions processed
<b>datums</b>	The number of datums processed
<b>datum_targets</b>	The number of datum targets processed
<b>tolerances</b>	The number of tolerances (all types combined) processed, regardless of composition.
<b>compos_tols</b>	The number of composite tolerances processed (number of instances of <code>geometric_tolerance_relationship</code> per section 6.9.9. in the PMI Rec. Pracs. v4.0.10).
<b>labels</b>	The number of labels processed

<b>column name</b>	<b>description</b>
<b>pmi_semantic_txt</b>	all/partial/none – whether 'semantic' (editable) PMI text was transferred correctly (content and associativity)
<b>pmi_semantic_val-prop</b>	all/partial/none – whether the validation properties for Semantic PMI Representation matched for all, some or none of the semantic PMI elements.
<b>saved_view</b>	The name of the Saved View which is the basis for the view-related statistics
<b>view_annot</b>	The number of annotations included in the specified saved view.
<b>view_pos</b>	pass/fail, whether the model orientation and zoom factor stored for the Saved View could be restored successfully.
<b>elem_visibility</b>	all/partial/none – whether all, some, or none of the elements to be displayed in the indicated saved view were mapped correctly into the corresponding draughting_model.
<b>pmi_savedview_valprop</b>	all/partial/none - whether the validation properties for PMI Saved Views matched for all, some or none of the views defined in the model.
<b>highlight</b>	all/partial/none – whether the cross-highlighting for annotations and annotated shape elements works correctly
<b>pmi_graphic_pres</b>	all/partial/none – whether the graphic PMI annotations included in the file could be processed correctly
<b>pmi_present_val-prop</b>	all/partial/none – whether the validation properties for Graphic PMI Presentation matched for all, some or none of the presentation elements.
<b>pmi_linked_pres_rep</b>	all/partial/none – whether the Semantic PMI Representation elements and (Graphic) PMI Presentation elements were linked correctly together.
<b>pmi_pres_placeholder</b>	all/partial/none - whether all, some, or none of the PMI Presentation Placeholders in the file were processed correctly.
<b>date</b>	The date when the statistics were last updated (will be filled in automatically)
<b>issues</b>	A short statement on issues with the file

## 2.2 APP: Assembly PMI Presentation

All information about this test case can also be viewed in CAESAR on its Information page.

### 2.2.1 Motivation

So far, PMI information – Graphic Presentation and Semantic Representation – has been dealt with mostly in the context of single parts. There is also the need to transfer PMI data in the context of assemblies. While in general, the PMI elements created in an assembly context are very similar to those created on single parts, the assembly structure adds additional levels of complexity:

- The target geometry for any PMI element needs to be identified within the correct instances of the target components within the assembly structure.
- For any Saved View defined at the assembly level, the appropriate scope of geometry needs to be included. This may include the full assembly, or only some of the components.
- All of this also needs to work across several files, to support the "nested assembly" approach.

Previous LOTAR pilots in the scope of LOTAR Part 125 have proven the concepts defined so far. These initial tests were based solely on one CATIA assembly. The next step is to test this capability on a broader scale in the CAX-IF, with a test model available in various native formats.

The tests done in LOTAR and in the CAX-IF so far have been based solely on MIM Part 21 as the implementation format. In round 49J, some vendors went ahead and added Semantic PMI Representation to the test. Anyone interested in testing this is encouraged to do so.

It needs to be pointed out, though, that future use cases for Assembly-level PMI, in the scope of LOTAR Part 126 as well as in the Automotive industry, are aiming at supporting PMI at the Assembly level in AP242 Edition 4 Domain Model XML format, with External Element References to the MIM Part 21 geometry. A first LOTAR pilot for this new implementation approach is planned for the end of 2022.

### 2.2.2 Approach

The approach to be used for Assembly-level PMI Presentation is defined in the PMI Recommended Practices, v4.0.10, which is available in the CAX-IF member area archive, under "Information on Round 49J of Testing". The approach needed for the APP test case in Round 50J is described in section 9.3.4, "Linking Annotations with Component Instances (Assembly PMI)".

**Note** that the formal evaluation of this test (the Statistics) focuses solely on the Graphic PMI Presentation.

In Round 50J, the tests shall be done using the "all-in-one" approach, i.e., exporting a single AP242 MIM Part 21 file containing, or using "Level 1" External Element References, i.e., having one AP242 MIM Part 21 file for the assembly structure, plus one AP242 MIM Part 21 file for each of the component parts (see PMI Rec. Pracs. section 9.4.2.4 and External Element References document v3.2).

Possible future extension of this test case may include hiding a component in an assembly-level Saved View (PMI Rec. Pracs. section 9.4.2.3) as well as moving on to the "nested" approach for the assembly structure.

### 2.2.3 Testing Instructions

The APP test case in Round 49J will use the "Vise" test model, courtesy of prostep ivip. This model is an assembly consisting of four parts with part-level PMI, which has been tested in the CAX-IF before.

For the purpose at hand the model has been extended to include PMI elements as well as a Saved View at the assembly level.

The native files for the "Vise" test model can be found in the File Repository within the CAX-IF member area, folder CAD/Round 49J/Vise. The model is available in three formats:

- CATIA V5 R30
- Creo 7
- NX 12

A PDF document with information about the included PMI is available in the same location.

Some of the assembly-level PMI might be academic, but this model has been deemed fit for the purpose until more industry-level multi-format assembly PMI test models become available.

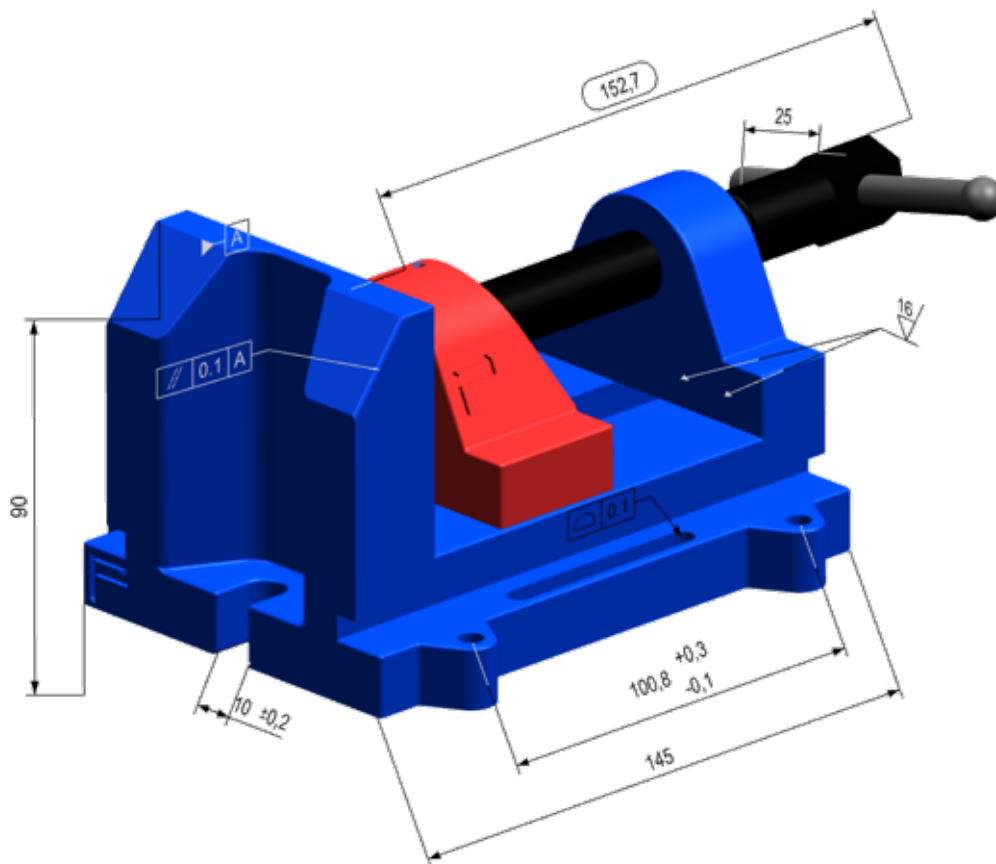

Figure 2: Illustration of the "Vise" test model; Saved View "MBD\_05"

## 2.2.4 Statistics

For each STEP file exported or imported for the APP test case, vendors must submit the corresponding statistics. To do so, go to the [ APP Data Sheet ], and either fill in the web form, or upload a comma-delimited file (.csv) with the data as listed below.

### Native Statistics

When exporting a STEP file, report what data importing systems should expect to find. For numeric statistics, enter the respective value or 'na' if not supported. For other statistics, select 'full support' (i.e. test case and Rec. Pracs. definitions are fulfilled), 'limited support' (meaning the implementation does not meet all criteria and issues may be expected on import), or 'na' if not supported.

### Target Statistics

When importing a file, report the results found after processing the file as described below.

## Data Sheet Columns

column name	description
<b>model</b>	The name of the test model, here 'km2'
<b>system_n</b>	The system code of the CAD system creating the STEP file
<b>system_t</b>	The system code of the CAD system importing the STEP file. For native stats, select 'stp'
<b>saved_view</b>	The name of the Saved View which is the basis for the view-related statistics
<b>view_annot</b>	The number of annotations included in the specified saved view.
<b>dimensions</b>	The number of dimensions processed
<b>datums</b>	The number of datums processed
<b>tolerances</b>	The number of tolerances (all types combined) processed, regardless of composition.
<b>labels</b>	The number of labels processed
<b>view_pos</b>	pass/fail, whether the model orientation and zoom factor stored for the Saved View could be restored successfully.
<b>elem_visibility</b>	all/partial/none - whether all, some, or none of the elements to be displayed in the indicated saved view were mapped correctly into the corresponding draughting_model.
<b>highlight</b>	all/partial/none - whether the cross-highlighting for annotations and annotated shape elements works correctly
<b>pmi_present_valprop</b>	all/partial/none - whether the validation properties for Graphic PMI Presentation matched for all, some or none of the presentation elements.
<b>date</b>	The date when the statistics were last updated (will be filled in automatically)
<b>issues</b>	A short statement on issues with the file

## 2.3 Test Case KM2: Kinematics

All information about this test case can also be viewed in CAESAR on its Information page.

### 2.3.1 Motivation

CAD methods have been used for many years now to design individual parts and assemblies of all sizes across all industries, from a single rivet to an entire airplane. Classically, the focus is to ensure that the part can be manufactured correctly.

Products such as cars, planes, or assembly lines are not static, however. They contain many moving components: engine, power windows, foldable roof, windshield wipers, cargo doors, etc. Thus, Kinematics are used to ensure they move correctly, as well as to illustrate the behavior of the finished product. The use cases cover the definition of the Kinematic Mechanism, providing all relationships and constraints between the elements so that their definition can be changed in the receiving application.

The goal is to use a neutral standard format – AP242 Domain Model XML – for the definition of the Kinematic mechanisms, with external references to the applicable geometry format for the respective use case.



### 2.3.2 Approach

The following schemas and documents shall be used for this test:

- Recommended Practices for AP242 Edition 3 Domain Model XML Kinematics, version 1.0, dated 26 November 2021, available on the public CAX-IF homepage under "CAX Recommended Practices".
- AP242 Edition 3 Domain Model XML, dated 11 May 2021, available in the CAX-IF member area under "Information on Round 48J of Testing". *If the schema is not yet available at the final URL stated in the Recommended Practices, please use a local copy of the schema.*

The Kinematic capabilities for AP242 XML are developed jointly by the CAX-IF and the JT-IF, thus supporting Aerospace as well as Automotive requirements, and a wider range of participating AP242 XML translators. Due to the schedule offset between the two groups, it allows for four rounds of testing of this topic per year. To ease the exchange of the files, the part geometry files for the KM2 test model are available in STEP AP242 Part 21 as well as ISO JT (JT v9.5) format, so the AP242 XML file references can easily be adapted for the preferred geometry format.

Based on this approach, Kinematic test files...

- From JT-IF Round 23 (February – June 2021) will be carried over to CAX-IF R50J.
- From CAX-IF R50J will be handed over to JT-IF Round 24 (August - November 2022).

**Note** that the passing the test cases between the two IF's requires replacing the geometry files as well as the file references in the AP242 XML file, but this has no impact on the actual Kinematic capabilities.

### 2.3.3 Testing Instructions

In Round 50J, a revised version of the Kinematics test model originally developed by Stefani Maschinenbau and provided by Audi and Volkswagen via the prostep ivip / VDA JT Workflow Forum will be used. It represents a gripper tool used in a production line assembly. This production-like model is used for internal pilot projects at Volkswagen and Audi and is being shared with the implementor forums for testing exclusively within these groups.

- The native CATIA version of the "Gripper" has been modeled by :em engineering methods on behalf of Audi. The ZIP package also contains an HTML breakdown of the model contents, also created by :em engineering methods.
- The native NX version of the "Gripper" has been modeled by Siemens PLM on behalf of Audi.
- The updated native CATIA and NX models are available in the CAX-IF member area under "Information on Round 50J of testing". Please make sure to use the latest version (upload date 14 June 2022).

**Note** that the models also contain PMI but checking these is out of scope for the KM2 test case, which solely focuses on the Kinematic definitions.

The following is in scope of Round 50J:

- Kinematic Mechanism includes the definition of kinematic pairs (joints and constraints) and actuators. The goal is that the mechanism is editable in the target system, while preserving the dependencies defined in the original system.
- Assembly & Kinematic Data shall be provided in a single AP242 XML file.
- Geometry shall be included as STEP AP242 Part 21 precise B-Rep files.
- Live Demonstration / Video of importing the Kinematic Mechanism into the target system and showing that it works as intended.



**Note** that the live demonstration of the successful import and movement of the Kinematic Mechanism can be given as a pre-recorded video. This video could be used at the following occasions:

- CAX-IF Round 50J Review Meeting
- MBx-IF User / Vendor Roundtable on 23 September
- prostep ivip / VDA JT Day in Ingolstadt on 29 September
- AFNeT / prostep ivip STEP AP242 Day in Munich on 20 October

Which of these events the video will be shown at is solely the decision of each vendor. The list is included to show it can be used more than once, recognizing the fact that the creation of such a video takes some effort.

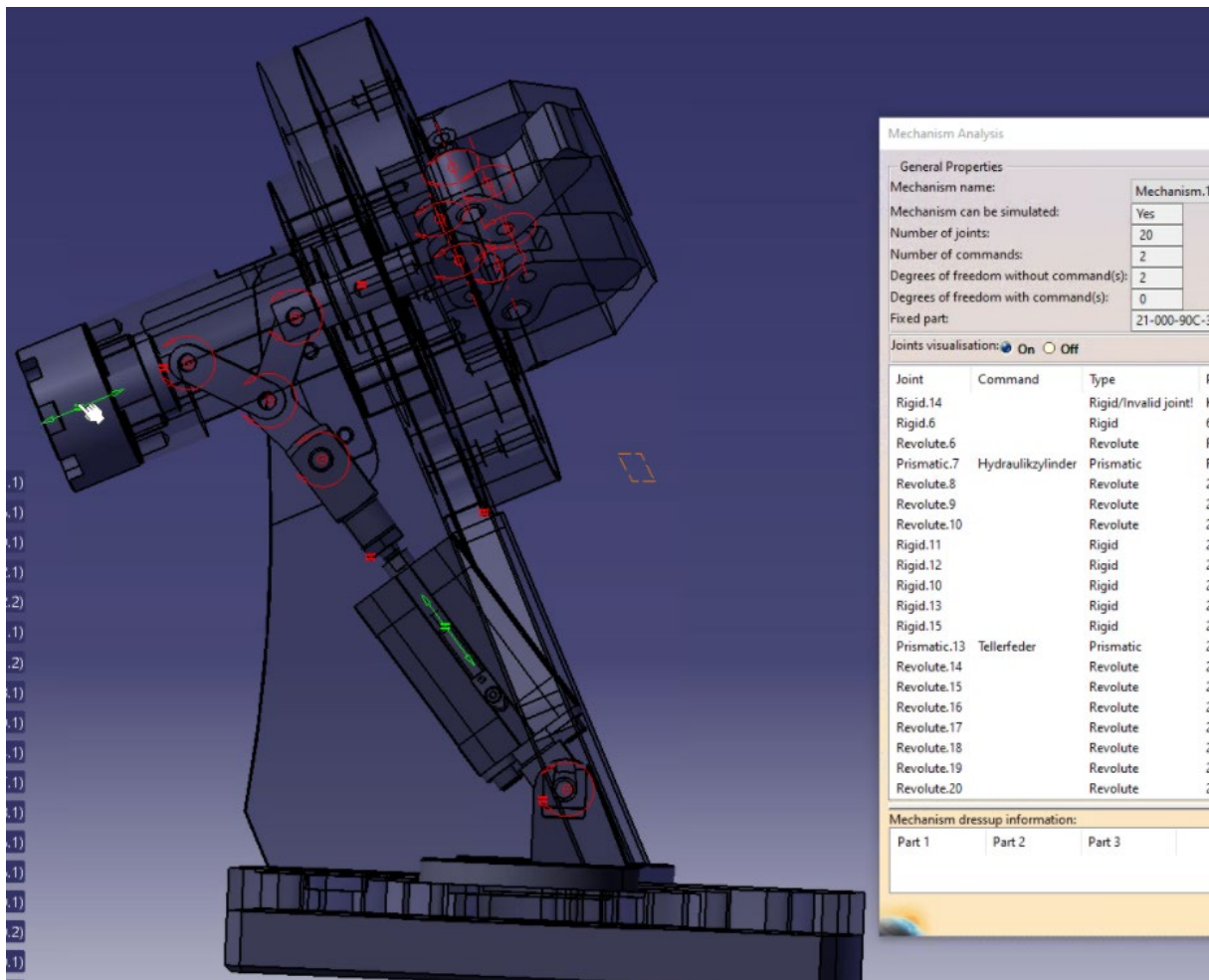

Figure 3: Illustration of the KM2 test model with indicated kinematic pairs

### 2.3.4 Statistics

For each STEP file exported or imported for the KM2 test case, vendors must submit the corresponding statistics. To do so, go to the [ KM2 Data Sheet ], and either fill in the web form, or upload a comma-delimited file (.csv) with the data as listed below.

#### Native Statistics

When exporting a STEP file, report what data importing systems should expect to find. For numeric statistics, enter the respective value or 'na' if not supported. For other statistics, select 'full support' (i.e. test case and Rec. Pracs. definitions are fulfilled), 'limited support' (meaning the implementation does not meet all criteria and issues may be expected on import), or 'na' if not supported.

#### Target Statistics

When importing a file, report the results found after processing the file as described below.

#### Kinematics-specific Statistics

For more detailed information about and discussion of in the Kinematics-specific statistics, please refer to section 4.12 of the Kinematics Recommended Practices mentioned above.

#### Data Sheet Columns

column name	description
model	The name of the test model, here 'km2'
system_n	The system code of the CAD system creating the STEP file
system_t	The system code of the CAD system importing the STEP file. For native stats, select 'stp'
assem_struct	pass/fail – if the model structure (assembly tree) was transferred correctly, i.e. no nodes have been added or removed, and all elements are on the correct hierarchical level.
kin_mechanisms	The number of Kinematic Mechanisms defined in the model
kin_moving_parts	Number of moving parts in a Kinematic Mechanism
kin_mech_pairs	The number of low/high order Kinematic Pairs defined for a Kinematic Mechanism
kin_placements	The number of AxisPlacements used by KinematicPairs
kin_revolute_pairs	The number of Revolute Pairs defined for Kinematic Mechanisms
kin_planar_pairs	The number of Planar Pairs defined for Kinematic Mechanisms
kin_cylindrical_pairs	The number of Cylindrical Pairs defined for Kinematic Mechanisms
kin_mech_acts	The number of Kinematic Pairs that have a non-zero value in the attribute 'actuation', i.e. where an initial movement can occur
valid_mechanism	pass/fail, whether the Kinematic Mechanism was successfully recognized by the target system and is moving as expected.
kin_limits	pass/fail, if the lower and upper limits defined for kinematic pairs were transferred correctly.
kin_mech_valprops	all/partial/none - whether the validation properties for Kinematic Mechanism matched for all, some or none of the Kinematic definitions.
date	The date when the statistics were last updated (will be filled in automatically)
issues	A short statement on issues with the file

## 2.4 Test Case UD4: User Defined Parameters

All information about this test case can also be viewed in CAESAR on its Information page.

### 2.4.1 Motivation

CAD models often contain user-defined parameters which define additional properties on the part. These can be parameters which drive the geometry (parametric definition), or engineering notes, requirements and custom properties that are relevant for downstream processes such as manufacturing.

These properties are typically authored in the source CAD systems and need to be transferred in a way that target applications can identify and process them in such a way that they make the appropriate decisions and derive relevant information for downstream use.

The CAX-IF User Group has defined several user stories related to user-defined properties and user-defined parameters at the part level as well as at the geometry level. The UD4 test case in Round 50J serves as an acceptance test for these user stories.

While the exact naming, structuring and association of these parameters to model elements – at part level as well as geometry level – differs between the different CAD systems based on their respective internal data models, they can be mapped to common concepts in STEP.

### 2.4.2 User Stories

This test case supports the following User Stories provided by the CAX-IF UG on Redmine:

ID	Title
<a href="#">#34</a>	User Defined Parameters at the part level
<a href="#">#35</a>	User Defined Properties at the part level
<a href="#">#36</a>	User Defined Parameters of a solid
<a href="#">#37</a>	User Defined Parameters of a geometric set
<a href="#">#38</a>	User Defined Parameters of surface, curves, point

### 2.4.3 Approach

The approach for transferring user-defined properties and parameters with STEP AP242 is described in the “Recommended Practices for User Defines Attributes”, version 1.8 (18 February 2021), which is available on the public web site of the CAX-IF Implementor Group. Specifically, section 5.3 of this document, which was newly introduced with version 1.7, provides the necessary classification mechanism to properly identify user-defined parameters and properties.

The precise mapping recommendation for testing user defined properties and parameters in Round 50J is as follows (all based on section 5.3 of the Recommended Practices):

- `id_attribute.attribute_value = 'general property'`
- `property_definition.description =`
  - 'customized PDM property' (for properties managed by the PLM system)
  - 'user defined attribute' (for user defined properties)

The schema to be used is the AP242 Edition 2 IS schema, available in the public area of the CAX-IF Implementor Group web page.

## 2.4.4 Testing Instructions

The CAX-IF User Group has provided a set of native CATIA V5 test models with pre-defined parameters and properties. These are available in a ZIP package from the member area of the CAX-IF web sites, under “Information on Round 47J of Testing.”

- The test model "ParameterTestPart\_simplified.CATPart" contains the basic parameters described in Figure 4 below.
- In addition, the test model "Parameter Test Part.CATPart" contains the complete set of Parameters/Properties that can be used.

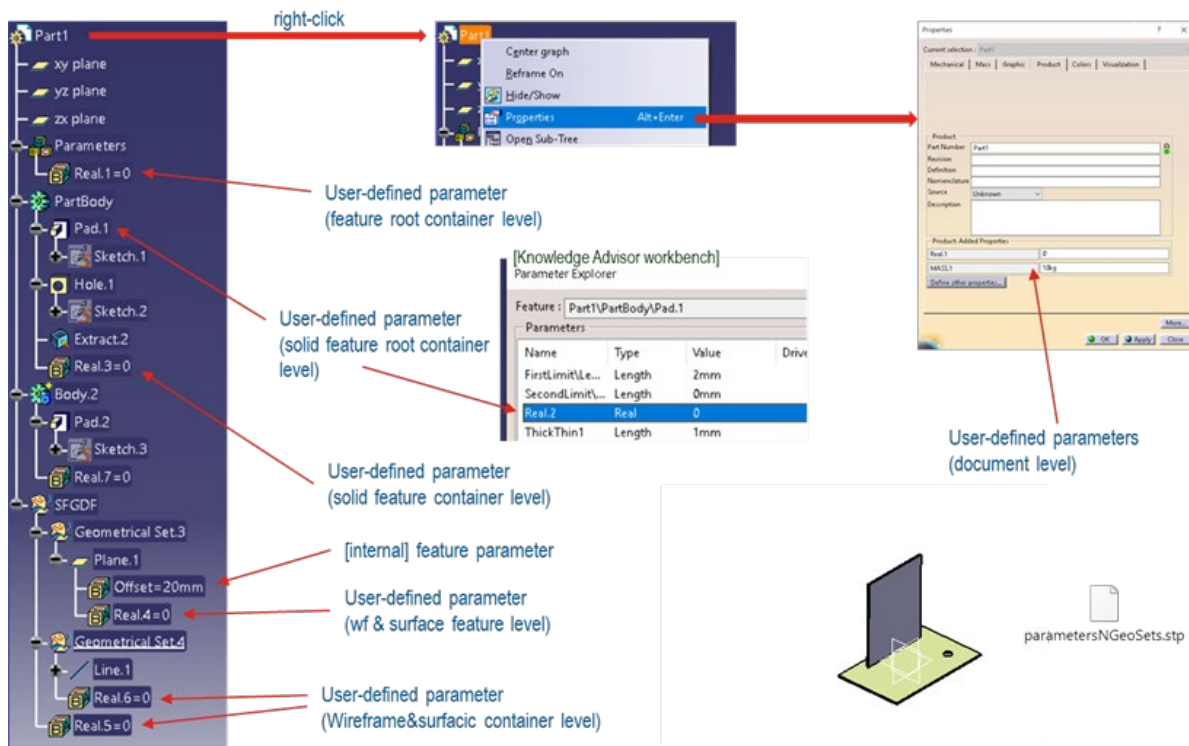

Figure 4: Overview on User-Defined Parameters and Properties defined in the test model

In addition, Siemens has provided an NX model (NX 1980) for the UD4 test case. The native file is available in the CAX-IF member area, under “Information on Round 50J of Testing.”

Figure 5 below provides an overview on the properties defined in the model.

The main objective for Round 50J, in addition to any roundtrip testing, is exchanging the information between CATIA-based and NX-based STEP interfaces to see whether the desired distinction between user-defined and system-managed properties is maintained across system boundaries.

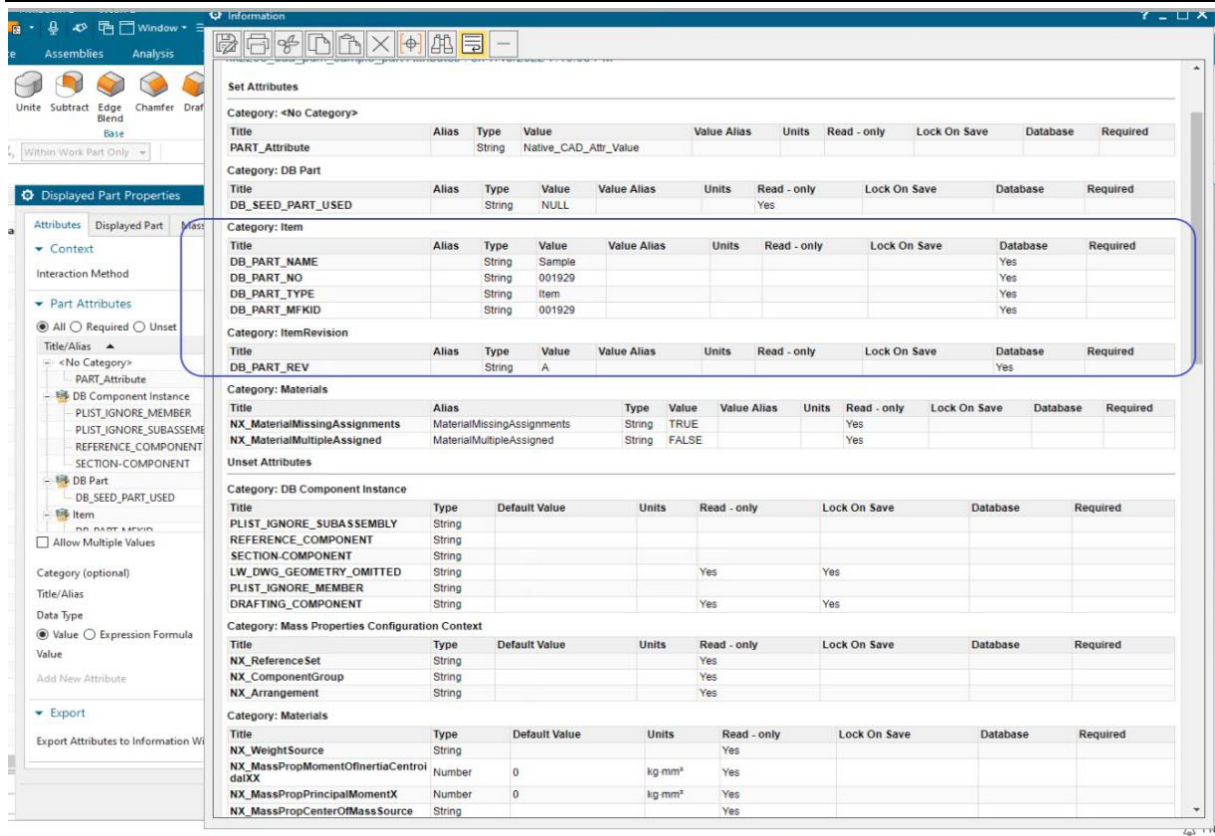

Figure 5: Overview on the Properties defined in the NX model for UD4.

## 2.4.5 Statistics

For each STEP file exported or imported for the UD4 test case, vendors must submit the corresponding statistics. To do so, go to the [ UD4 Data Sheet ], and either fill in the web form, or upload a comma-delimited file (.csv) with the data as listed below.

### Native Statistics

When exporting a STEP file, report what data importing systems should expect to find. For numeric statistics, enter the respective value or 'na' if not supported. For other statistics, select 'full support' (i.e. test case and Rec. Pracs. definitions are fulfilled), 'limited support' (meaning the implementation does not meet all criteria and issues may be expected on import), or 'na' if not supported.

### Target Statistics

When importing a file, report the results found after processing the file as described below.



## Data Sheet Columns

column name	description
<b>model</b>	The name of the test model, here 'ud4'
<b>system_n</b>	The system code of the CAD system creating the STEP file
<b>system_t</b>	The system code of the CAD system importing the STEP file. For native stats, select 'stp'
<b>ud_param_part</b>	pass / fail, have the user defined parameters at part / product level been transferred correctly?
<b>ud_prop_part</b>	pass / fail, have the user defined properties at part / product level been transferred correctly?
<b>ud_param_solid</b>	pass / fail, have the user defined parameters for solids been transferred correctly?
<b>ud_param_geoset</b>	pass / fail, have the user defined parameters for CATIA geometric sets been transferred correctly?
<b>ud_param_scp</b>	pass / fail, have the user defined parameters for surfaces, curves and points been transferred correctly?
<b>valid_attr</b>	pass/fail, is the instantiation of the User Defined Attributes as per the Recommended Practices?
<b>uda_part_vp</b>	pass/fail, has the number of User Defined Attributes at the Part/Product level been processed correctly? This includes UDA VP at assembly component instances and for groups of UDA.
<b>uda_geo_vp</b>	pass/fail, has the number of User Defined Attributes at the Geometry level been processed correctly?
<b>uda_type_vp</b>	pass/fail, has the number of User Defined Attributes per attribute type class (boolean/integer/real/string) been processed correctly?
<b>date</b>	The date when the statistics were last updated (will be filled in automatically)
<b>issues</b>	A short statement on issues with the file

## 2.5 Test Case AS3: AP242 Edition 2 Minor Revision Domain Model XML

All information about this test case can also be viewed in CAESAR on its Information page.

### 2.5.1 Motivation

The exchange of assembly structures with external references to geometry files is a long-used concept in the STEP multiverse, which has proven its value and stability in many business use cases. In addition to the long-used Part 21 representation, AP242 Edition 2 provides a Domain Model with a comprehensive data model in an XML representation.

AP242 XML is the designated standard process format for the automotive and aerospace industries and will be used together with various standardized and proprietary geometry file formats, depending on the actual use case. Over time, this test case evolved to include external references to 3D Tessellated Geometry, Assembly Validation Properties and User Defined Attributes.

The second edition of AP242 was published in April 2020, which brought with it many changes in the underlying architecture of the standard as well as extended functionalities. However, some limitations and issues remained with the data model. These have now been resolved with AP242 Edition 3. While the standard document is currently going through the release process, the final implementation schemas and updated Recommended Practices are available for vendors to update their translators.

In Round 50J, this test case is dedicated to the migration towards AP242 Edition 3.

Only AP242 Ed.3 files will be accepted for testing in the AS3 test case.

### 2.5.2 Approach

The following schemas and documents shall be used for this test:

- Recommended Practices for AP242 Edition 3 Domain Model XML Product and Assembly Structure, version 3.0, dated 23 November 2021, available on the public CAX-IF homepage under "CAX Recommended Practices".
- AP242 Edition 3 Model XML, dated 11 May 2021, available in the CAX-IF member area under "Information on Round 48J of Testing". *As long as the schema is not yet available at the final URL stated in the Recommended Practices, please use a local copy of the schema.*

The focus of this test is the assembly structure exchanged in AP242 XML format. The test has the following degrees of freedom:

#### File structure:

- "all in one" - one XML file for the entire assembly structure, plus one STEP file per component part
- "nested" - one XML file for each node in the assembly tree, plus one STEP file per component part. Note that in this case, component parts with part-level User Defined Attributes require an additional Domain Model XML sidecar file containing these properties; see Recommended Practices section 9.3.

#### Geometry format:

- Precise B-Rep (STEP AP242) or Tessellated Geometry (STEP AP242)



### 2.5.3 Testing Instructions

The test model to be used in Round 50J is the "Torque Converter", known from previous Benchmarking activities. Native CAD files are available for it in the following formats:

- CATIA V5
- Creo
- NX

These can be found in the File Repository within the member area of the CAX-IF web sites, in the folder "/CAD/Round 41J/Torque Converter".

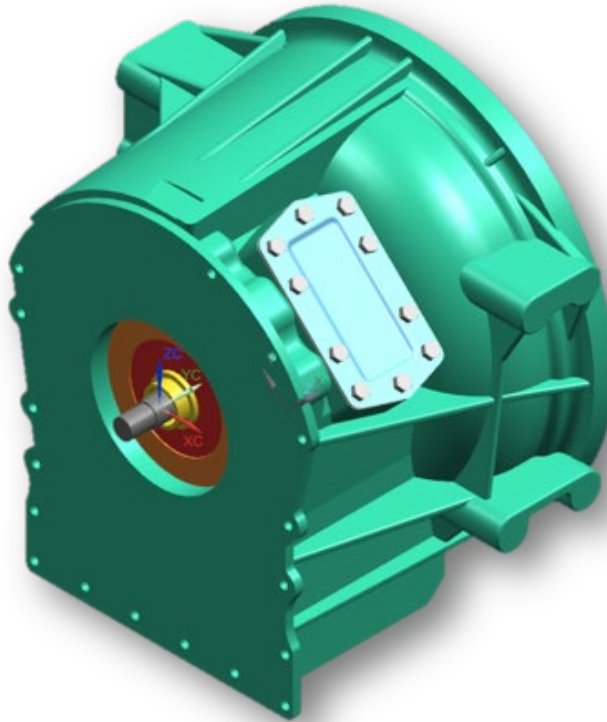

*Figure 6: Illustration of the Torque Converter model*

The aim of this test is to correctly transfer the assembly structure based on AP242 Edition 2 Minor Revision Domain Model XML files, using either the "all-in-one" or the "nested" approach, and referencing tessellated parts.

Since transfer of the AS3 geometry itself can safely be considered stable, there will be no geometry-related statistics. The evaluation will focus on completeness and correctness of the assembly structure and the external references.

The assembly files shall contain Assembly Validation Properties for all nodes in the product structure. The two values – number of children, and notional solids centroid – and their representation are defined in section 13.1 of the AP242 Edition 3 Domain Model XML Assembly Structure Recommended Practices.

In addition, all CAX-IF members supporting User Defined Attributes shall transfer the ones included in the native files (see below) at part level (section 12.5.1 of the Recommended Practices).

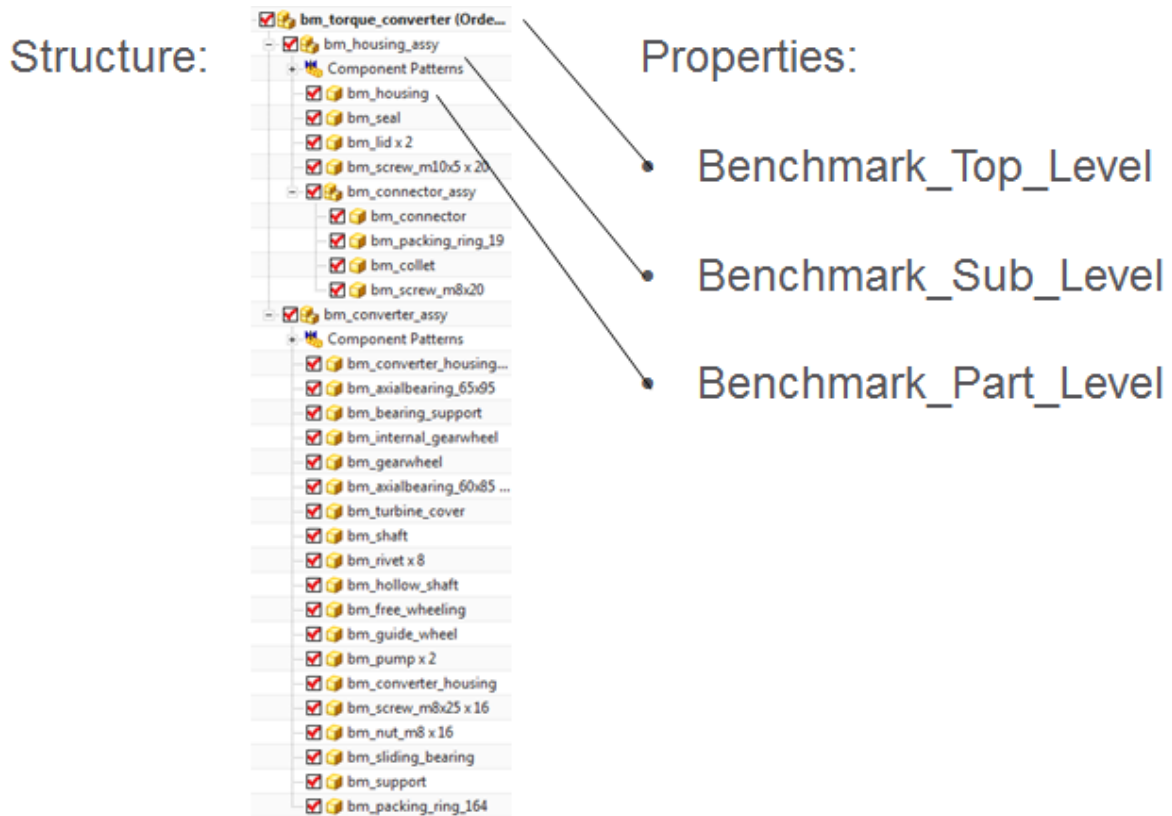

Figure 7: Torque Converter structure and indication of included attributes

## 2.5.4 Statistics

For each STEP file exported or imported for the AS3 test case, vendors must submit the corresponding statistics to CAESAR. To do so, go to the [ AS3 Data Sheet ], and either fill in the web form, or upload a comma-delimited file (.csv) with the data as listed below.

### Native Statistics

When exporting a STEP file, report what data importing systems should expect to find. For numeric statistics, enter the respective value or 'na' if not supported. For other statistics, select either 'full support' (i.e. test case and Rec. Pracs. definitions are fulfilled), 'limited support' (meaning the implementation does not meet all criteria and issues may be expected on import), or 'na' if not supported.

### Target Statistics

When importing a STEP file, report the results found after processing the file as described in the table below.

## Data Sheet Columns

column name	description
<b>model</b>	The name of the test model, here: 'AS3'
<b>system_n</b>	The system code of the CAD system creating the STEP file
<b>system_t</b>	The system code of the CAD system importing the STEP file. For native stats, enter 'stp'
<b>fref_found</b>	all/partial/none - indicates if all, some or none of the references to the external files can be found in the assembly structure file(s), and if they are correctly associated with the respective nodes in the assembly structure.
<b>fref_processed</b>	all/partial/none - indicates if all, some or none of the referenced files were processed correctly to successfully construct the overall model.
<b>assem_struct</b>	pass/fail - if the model structure (assembly tree) was transferred correctly, i.e. no nodes have been added or removed, and all elements are on the correct hierarchical level.
<b>assem_place</b>	all/partial/none - whether the placement of assembly components is correct
<b>children</b>	pass/fail, indicates whether the number of children for each node in the assembly tree matches the AVP value given in the STEP file
<b>valid_child</b>	pass/fail, is the instantiation of the validation property 'number of children' in the STEP file as per the recommended practices for validation properties?
<b>notional_solids</b>	all/partial/none, whether the position of all, some or none of the assembly components in the model could be validated through the 'notional solids' AVP.
<b>valid_notion</b>	pass/fail, is the instantiation of the validation property 'notional solids' in the STEP file as per the recommended practices for validation properties?
<b>part_attr</b>	pass/fail, have the User Defined Attributes at the part/product level been processed correctly?
<b>date</b>	The date when the statistics were last updated (will be filled in automatically)
<b>issues</b>	A short statement on issues with the file

## 2.6 Test Case CO4: Composite Part with Multiple Rosette

All information about this test case can also be viewed in CAESAR on its Information page.

### 2.6.1 Motivation

For several years, some STEP composite interfaces have been available in several CAD tools such as CATIA V5, FiberSIM and in CT CoreTechnologie tools, with a certain level of maturity proven by LOTAR pilot projects.

The goal of including Composite Materials in a CAX-IF test round is to align these implementations and provide an official framework for composite materials implementation tests as STEP AP242 Edition 2 includes this capability.

The CAX-IF User Group created a user story with the requirement to convert a composite part with multiple rosettes within a ply group to STEP in a way that preserves the design intent.

### 2.6.2 User Stories

This test case supports the following User Stories provided by the CAX-IF UG on Redmine:

ID	Title
<a href="#">#17</a>	Multiple Rosette in Ply Group

### 2.6.3 Approach

For multiple rosettes inside the same ply group, the aim of the test is to take two plies inside the same ply group that do not have the same rosette, then to check that after STEP export/import that this is still the case.

As an example, in the given test case (see Figure 8 below),

- Ply “Ply.5” has the rosette “Rosette - Pad 1”
- Ply “Ply.6” has the rosette “Rosette - Pad 3”
- Plies “Ply.3” and “Ply.5” are both in the same group “Laminate Table 1 - Multiple Rosette Example”

The basis for implementation of the CO4 test case is the following:

- AP242 Edition 2 IS Longform Express Schema, available on the CAX-IF homepage under “Public Testing Information”.
- Recommended Practices for Composite Materials; Version 4.2; 17 August 2021; available on the public MBx-IF homepage under “CAX Interoperability Forum > Implementor Group > CAX Recommended Practices”.

### 2.6.4 Testing Instructions

The test case “MultipleRosettesUseCase\_RevA.CATPart” will be used. The model has been provided by the CAX-IF User Group.

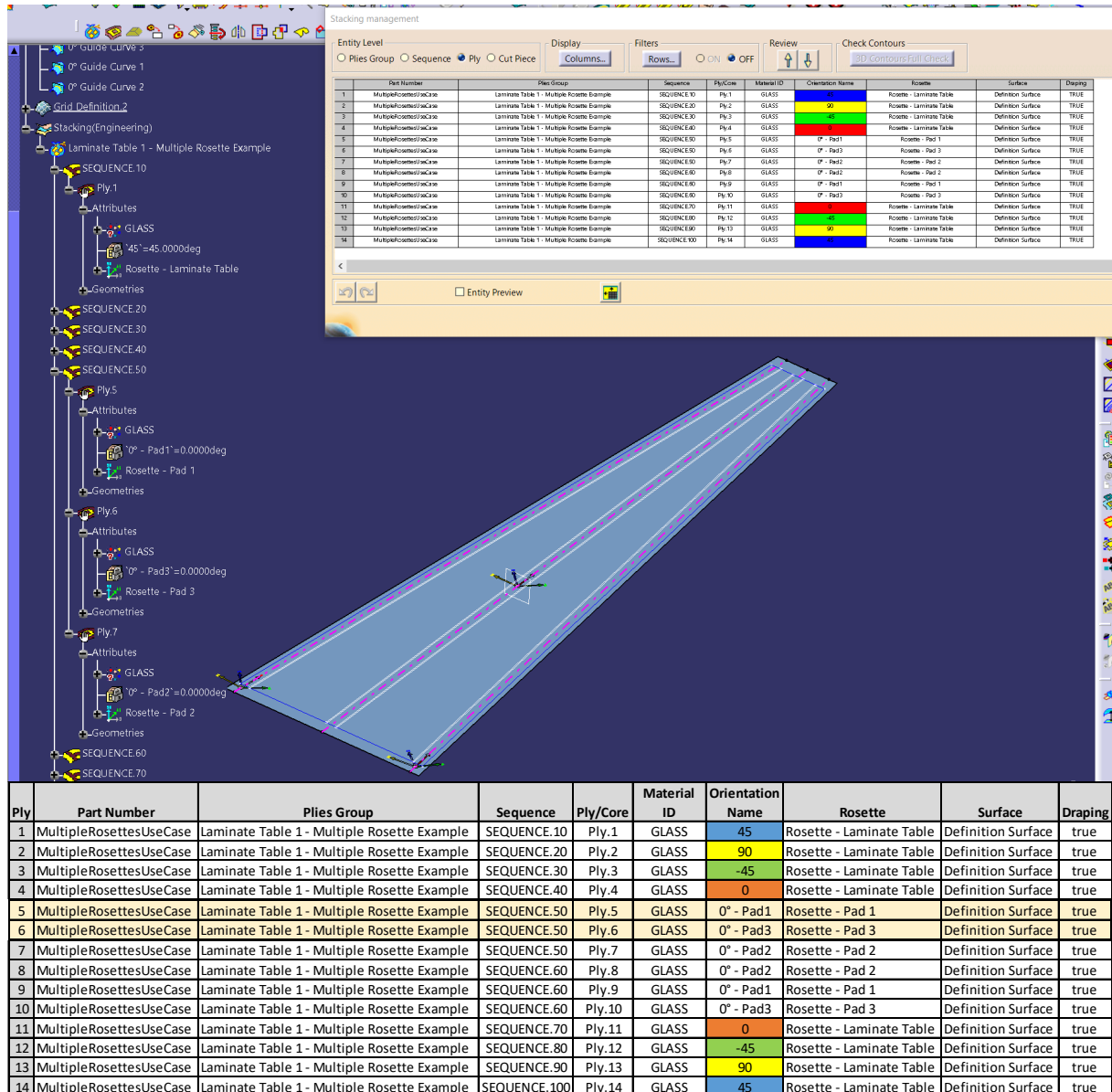

Figure 8: Illustration of the CO4 Test Case and Laminate Table

The test case is available in the member area of the CAX-IF homepages, under “Information on Round 48J of Testing”.

### 2.6.5 Statistics

For each STEP file exported or imported for the CO4 test case, vendors must submit the corresponding statistics. To do so, go to the [ CO4 Data Sheet ], and either fill in the web form, or upload a comma-delimited file (.csv) with the data as listed below.

#### Native Statistics

When exporting a STEP file, report what data importing systems should expect to find. For numeric statistics, enter the respective value or 'na' if not supported. For other statistics, select either 'full support' (i.e. test case and Rec. Pracs. definitions are fulfilled), 'limited support' (meaning the implementation does not meet all criteria and issues may be expected on import), or 'na' if not supported.

## Target Statistics

When importing a STEP file, report the results found after processing the file as described in the table below.

## Ply-related Statistics

Several of the Statistics for this test case are related to a specific ply within a specific sequence (e.g., material, orientation, rosette). The statistics cannot evaluate this for all plies in the model. Hence, the idea is to select one specific (interesting) sequence and ply on export, and to publish its name in the "Composite Ply Sequence" field of the statistics. Then, fill in the other ply-related statistics with the values as valid for this particular sequence and ply. After import, select the sequence and ply with the name given in the native statistics, and again provide the values valid for this particular sequence and ply.

The plies group to be used for evaluating the CO4 test case in Round 50J is:

**Laminate Table 1 - Multiple Rosette Example**

The plies to be used for evaluating the CO4 test case in Round 50J are:

**PLY.5, PLY.6**

## Data Sheet Columns

column name	description
<b>model</b>	The name of the test model, here 'CO4'
<b>system_n</b>	The system code of the CAD system creating the STEP file
<b>system_t</b>	The system code of the CAD system importing the STEP file. For native stats, select 'stp'
<b>unit</b>	The unit the model is designed in
<b>compos_tables</b>	The number of Composite Tables in the Model
<b>compos_table_name</b>	The name of the Composite Table of the model
<b>plies</b>	The total number of plies in the model
<b>plies_groups</b>	The total number of plies groups in the model
<b>rosettes_pg</b>	The number of rosettes in the plies group selected for this test
<b>multi_rosettes</b>	pass/fail, do the selected plies within the same plies group have multiple rosettes assigned.
<b>date</b>	The date when the statistics were last updated (will be filled in automatically)
<b>issues</b>	A short statement on issues with the file

## 2.7 Test Case CO5: Composite Part with Rosette Guided by a Curve 90°

All information about this test case can also be viewed in CAESAR on its Information page.

### 2.7.1 Motivation

For several years some STEP composite interfaces have been available in several CAD tools such as CATIA V5, FiberSIM and in CT CoreTechnologie tools, with a certain level of maturity proven by LOTAR pilot projects.

The goal of including Composite Materials in a CAX-IF test round is to align these implementations and provide an official framework for composite materials implementation tests as STEP AP242 Edition 2 includes this capability.

The CAX-IF User group provided a user story including a composite part with Rosette Guided by a curve, where the primary direction is set to non-zero (i.e., 90°). The goal is to archive the data for certification, as well as exchanging it with a manufacturing supplier.

### 2.7.2 User Stories

This test case supports the following User Stories provided by the CAX-IF UG on Redmine:

ID	Title
<a href="#">#141</a>	Rosette Guided by a curve 90°

### 2.7.3 Approach

The aim of this test is to transfer the rosettes defined in the part, the relationship to the respective guide curve, as well as the respective orientation as defined in the native model.

The table in section 2.7.5 provides the details for the given test model.

The basis for implementation of the CO5 test case is the following:

- AP242 Edition 2 IS Longform Express Schema, available on the CAX-IF homepage under "Public Testing Information".
- Recommended Practices for Composite Materials; Version 4.2; 17 August 2021; available on the public MBx-IF homepage under "CAX Interoperability Forum > Implementor Group > CAX Recommended Practices".

### 2.7.4 Testing Instructions

The native model is the file "ASME\_Y14.37\_RosetteType2\_90GuidedByCurve\_A.CATPart", which is available in the member area of the CAX-IF homepage under "Information on Round 49J of Testing". This model has been provided by the CAX-IF User Group.



## Type II – Guide Curve - 90 deg along curve

— 0 deg.  
— 90 deg.

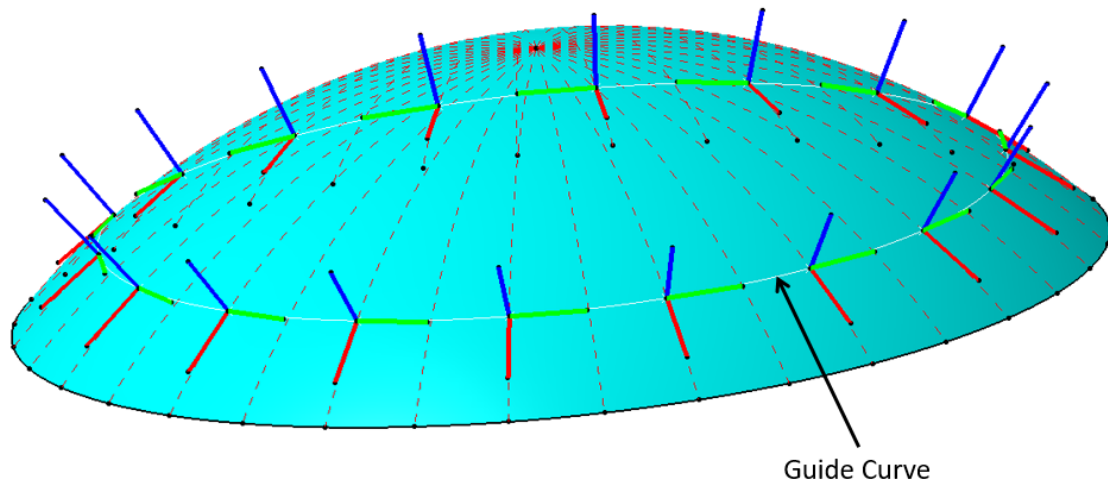

Figure 9: Illustration of the CO5 Test Case

### 2.7.5 Statistics

For each STEP file exported or imported for the CO5 test case, vendors must submit the corresponding statistics. To do so, go to the [ CO5 Data Sheet ], and either fill in the web form, or upload a comma-delimited file (.csv) with the data as listed below.

#### Native Statistics

When exporting a STEP file, report what data importing systems should expect to find. For numeric statistics, enter the respective value or 'na' if not supported. For other statistics, select either 'full support' (i.e. test case and Rec. Pracs. definitions are fulfilled), 'limited support' (meaning the implementation does not meet all criteria and issues may be expected on import), or 'na' if not supported.

#### Target Statistics

When importing a STEP file, report the results found after processing the file as described in the table below.

#### Scope-specific Statistics:

The following table lists the key parameters define in the test model. In order for the test to be considered a success, the following information must be preserved during the exchange:

- Name of the Rosette
- Name of the associated Guide Curve
- Orientation Angle

The statistics gathered in CAESAR will record whether all, some, or none of there were transferred successfully.

Sequence	Ply	Core Material ID	Orientation	Rosette	Guide Curve
Sequence.1	Ply 1	10745	0°	Rosette A	Guide_Curve_90_Rosette A
Sequence.2	Ply 2	10745	45°	Rosette A	Guide_Curve_90_Rosette A
Sequence.3	Ply 3	10745	-45°	Rosette A	Guide_Curve_90_Rosette A
Sequence.4	Ply 4	10745	90°	Rosette A	Guide_Curve_90_Rosette A
Sequence.5	Ply 5	10745	0° or 90°	Rosette A	Guide_Curve_90_Rosette A
Sequence.6	Ply 6	10745	+45° or -45°	Rosette A	Guide_Curve_90_Rosette A

#### Data Sheet Columns

column name	description
<b>model</b>	The name of the test model, here 'CO4'
<b>system_n</b>	The system code of the CAD system creating the STEP file
<b>system_t</b>	The system code of the CAD system importing the STEP file. For native stats, select 'stp'
<b>rosette_names</b>	all/partial/none - whether all, some, or none of the Rosette names for Ply X of Sequence Y have been transferred correctly per the test case definition.
<b>rosette_curve_names</b>	all/partial/none - whether all, some, or none of the names of the curves related to the Rosettes have been transferred correctly per the test case definition.
<b>orientation_values</b>	all/partial/none - whether all, some, or none of the orientation values for Ply X of Sequence Y have been transferred correctly per the test case definition.
<b>date</b>	The date when the statistics were last updated (will be filled in automatically)
<b>issues</b>	A short statement on issues with the file

## 2.8 Test Case ASR: Alternative Shape Representation with PMI

All information about this test case can also be viewed in CAESAR on its Information page.

### 2.8.1 Motivation

Several scenarios have been discussed that require storing more than one shape for a particular part, the main use case being storing the precise B-Rep shape and the equivalent tessellated shape of the same part version and view within one STEP file.

In Round 50J, the scope is extended by adding PMI data to the model. The goal is to ensure that the linking between PMI and part shape still works consistently, so design intent as well as features such as cross-highlighting are preserved.

### 2.8.2 Approach

The approach to be used for the alternative shape representations is described in the draft Recommended Practices for Alternative Shapes, version 0.2, dated 23 November 2021. This test case relates to section 5 of this document, "Alternative Representations for Equivalent Part Shapes".

For the PMI definitions, Graphic as well as Semantic, the PMI Recommended Practices v4.0.10 apply.

Both Recommended Practices can be found in the member area of the CAX-IF homepages, under "Information on Round 49J of Testing".

In addition, the Tessellated Shape shall be linked to the exact B-Rep Shape, following section 5.4.5 in the Recommended Practices for Tessellated 3D Geometry. This document can be found in the public area of the CAX-IF homepages.

Test files can be provided as either AP242 Edition 2 or as AP242 Edition 3. The schemas are available on the public CAX-IF web site.

### 2.8.3 Testing Instructions

The model used for this test is NIST's CTC-5 model, which can be obtained from <https://go.usa.gov/xuh9n>. Also see the definition of the PMI Test Case in section 2.1.4 for more information about the NIST models.

Each STEP file submitted for the ASR test case shall contain:

#### Alternative Shapes

- The part shape as precise advanced B-Rep
- The equivalent Tessellated Shape, following the structure given in Figure 2 or 3 of the draft Rec. Practices for Alternative Part Shapes
- Links between the Tessellated Shape and the exact B-Rep Shape, following section 5.4.5 of the Recommended Practices for Tessellated 3D Geometry.

#### PMI

- Semantic PMI Representation as well as Graphic PMI Presentation
- Both representations shall be linked to the precise B-Rep shape.
- Cross-highlighting on the Tessellated Shape shall work by following the links between B-Rep and Tessellated geometry.

#### Validation Properties

- Include the applicable Validation Properties (Geometric, Tessellated, PMI).



## Relation of Statistics to Test Scope

- *Volume, Area, and Centroid* apply to the B-Rep Shape
- *Number of Facets* applies to the Tessellated Shape
- *Alternative Shapes* applies to the link between the shapes
- *PMI Graphic Presentation, Cross Highlight and Valid PMI Presentation VP* apply to Graphic PMI Presentation
- *Number of Dimensions, Number of Tolerances and Valid PMI Semantic VP* apply to Semantic PMI Representation.

## Data Sheet Columns

column name	description
<b>model</b>	The name of the test model, here: 'IO1'
<b>system_n</b>	The system code of the CAD system creating the STEP file
<b>system_t</b>	The system code of the CAD system importing the STEP file. For native stats, enter 'stp'
<b>unit</b>	The unit the model is designed in
<b>volume</b>	Total volume of all solids
<b>area</b>	Total surface area of all solids
<b>cx</b>	Centroid of the model
<b>cy</b>	
<b>cz</b>	
<b>facets</b>	The number of facets in the Tessellated model
<b>alt_shapes</b>	all/partial/none - whether the alternative part shapes in the model were processed correctly
<b>pmi_graphic_pres</b>	all/partial/none - whether the graphic PMI annotations included in the file could be processed correctly
<b>highlight</b>	all/partial/none - whether the cross-highlighting for annotations and annotated shape elements works correctly
<b>pmi_present_valprop</b>	all/partial/none - whether the validation properties for Graphic PMI Presentation matched for all, some or none of the presentation elements.
<b>date</b>	The date when the statistics were last updated (will be filled in automatically)
<b>issues</b>	A short statement on issues with the file

## Annex A NIST Model Translation Configuration Considerations

Based on data translation issues identified in the NIST Phase 2 project (requiring multiple dataset submission iterations to resolve), the following translator configuration considerations have been derived for the PMI test case in Round 50J:

- Include annotations, coordinate systems, model properties, and PMI views
- Include supplemental geometry (non-solid surfaces, curves, points)
- Preserve annotation associations with both product and supplemental geometry
- Preserve annotation semantic PMI properties
  - Clearly point out if these are intentionally not translated
- Preserve annotation text
  - Creo should be configured to display dimension tolerances (tol\_display on)
  - Do not drop leading zeros or add trailing zeros
- Preserve annotation units
  - CTC 01, 02, and 04 are defined in millimeters
  - CTC 03 and 05 are defined in inches
  - FTC 06 through 09 models are defined in inches
  - FTC 10 and 11 models are defined in millimeters
- Preserve display names of annotations and coordinate systems
  - Point out if you use NX 9 or newer since this will change some of the annotation names (see Figure 11 below)
- Preserve display colors of product geometry, supplemental geometry, and annotations
- Preserve view-specific visibility of annotations, coordinate systems, and supplemental geometry:
  - In the ZIP files with the test case specifications (see links in section 2.1.4), there is a PDF named "*nist\_[ctc/ftc]\_suppl\_elem\_visibility.pdf*" which gives a detailed definition of which elements shall be visible in which view, and which not.
  - Note that for each test case, there is a second PDF document included in the ZIP files, named "*...\_elem\_ids.pdf*" which contains the element ids for unambiguous identification of all PMI.
- Preserve view frustum (orientation and zoom level) definition:
  - JT model views should be defined so they are listed in the "Model Views" menu of JT2Go and work properly when selected
- Do not export extraneous information
  - Only CATIA Captures (not Views) should be exported to STEP Saved Views
  - Creo sketch dimensions should only be included when visible in a Combined View



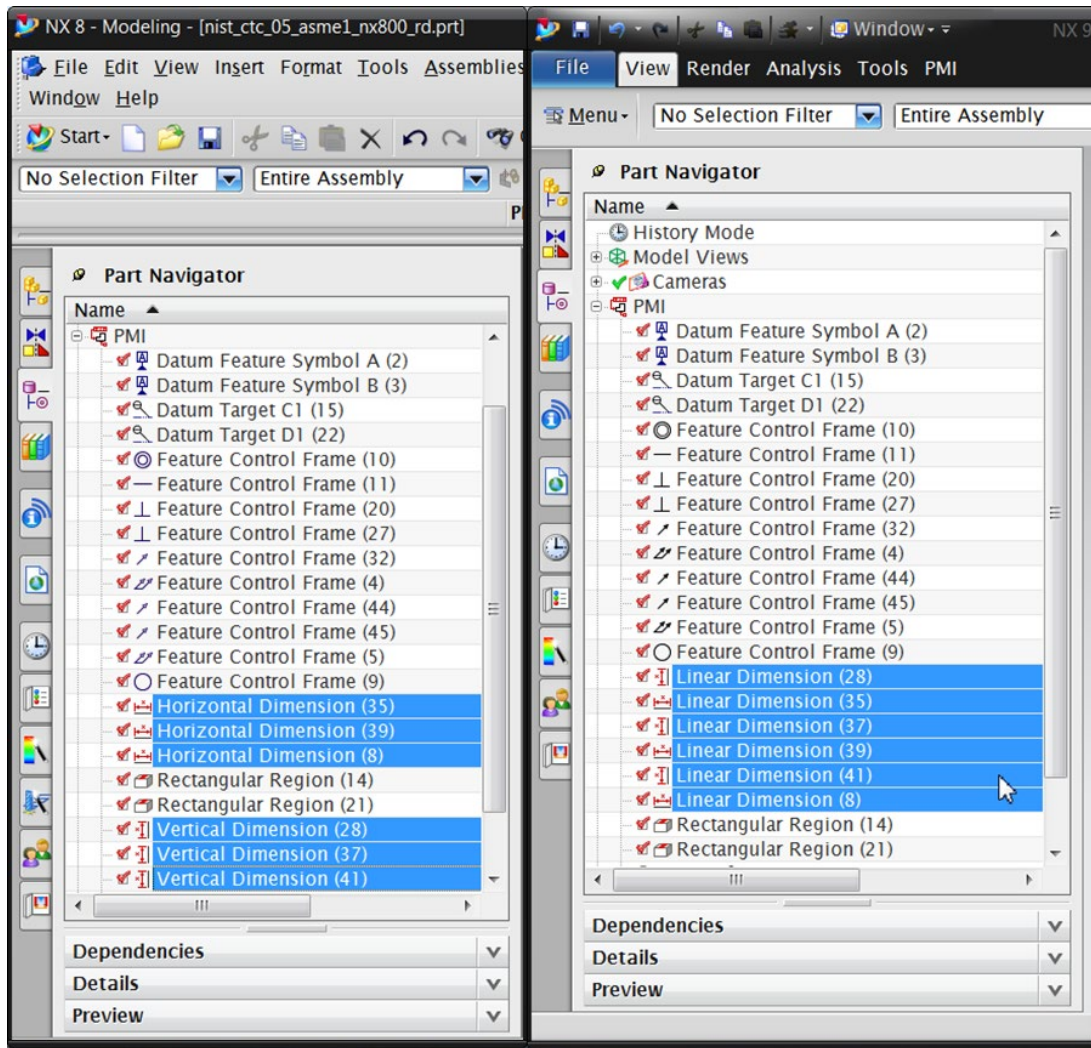

Figure 11: NX 8 vs. NX 9 Dimension Display Names











### NIST PMI Test Models - 2014

NOTES (UNLESS OTHERWISE SPECIFIED):

- CAD MODEL \_\_\_\_\_ REV. \_\_\_\_ IS REQUIRED TO COMPLETE PRODUCT DEFINITION.
- DIRECTLY-TOLERANCED DIMENSIONS AND BASIC DIMENSIONS DEFINED ON THE DRAWING TAKE PRECEDENCE OVER DIMENSIONAL DATA DEFINED BY THE MODEL. OBTAIN ALL OTHER DIMENSIONAL DATA FROM THE MODEL. THE MODEL REPRESENTS BASIC DIMENSIONAL DATA UNLESS OTHERWISE SPECIFIED.
- APPLICABLE STANDARDS:  
 ASME Y14.41-2003 APPLIES TO DATASET.  
 ASME Y14.5M-1994 APPLIES TO DIMENSIONING AND TOLERANCING.
- $\text{[Symbol: Surface Texture]} .05 \text{ [A] [B] [C]}$  APPLIES TO ALL UNTOLERANCED SURFACES.
- UNITS: INCHES

Feature and Specification Index  
R50J

**PMI Fully-Toleranced Test Case 6 - View A**  
 Includes Atomic Test Cases - 52, 53, 72, 87, 88, 89

Rev D nist\_ftc\_06\_asme1\_rd

### NIST PMI Test Models - 2014

NOTES (UNLESS OTHERWISE SPECIFIED):

- CAD MODEL \_\_\_\_\_ REV. \_\_\_\_ IS REQUIRED TO COMPLETE PRODUCT DEFINITION.
- DIRECTLY-TOLERANCED DIMENSIONS AND BASIC DIMENSIONS DEFINED ON THE DRAWING TAKE PRECEDENCE OVER DIMENSIONAL DATA DEFINED BY THE MODEL. OBTAIN ALL OTHER DIMENSIONAL DATA FROM THE MODEL. THE MODEL REPRESENTS BASIC DIMENSIONAL DATA UNLESS OTHERWISE SPECIFIED.
- APPLICABLE STANDARDS:  
 ASME Y14.41-2003 APPLIES TO DATASET.  
 ASME Y14.5M-1994 APPLIES TO DIMENSIONING AND TOLERANCING.
- $\text{[Symbol: Surface Texture]} .06 \text{ [A] [B] [C]}$  APPLIES TO ALL UNTOLERANCED SURFACES.
- FEATURES IDENTIFIED AS STATISTICALLY TOLERANCED (ST) SHALL BE PRODUCED WITH STATISTICAL PROCESS CONTROLS OR TO THE MORE RESTRICTIVE ARITHMETIC LIMITS SPECIFIED. DETAILED PROCESS PLAN NEEDED TO COMPLETELY DEFINE STATISTICAL PARAMETERS AND REQUIREMENTS.
- UNITS: INCHES

Feature and Specification Index  
R50J

**PMI Fully-Toleranced Test Case 7 - View A**  
 Includes Atomic Test Cases - 84, 85

Rev D nist\_ftc\_07\_asme1\_rd

### NIST PMI Test Models - 2014

NOTES (UNLESS OTHERWISE SPECIFIED):

- CAD MODEL \_\_\_\_\_ REV. \_\_\_\_ IS REQUIRED TO COMPLETE PRODUCT DEFINITION.
- DIRECTLY-TOLERANCED DIMENSIONS AND BASIC DIMENSIONS DEFINED ON THE DRAWING TAKE PRECEDENCE OVER DIMENSIONAL DATA DEFINED BY THE MODEL. OBTAIN ALL OTHER DIMENSIONAL DATA FROM THE MODEL. THE MODEL REPRESENTS BASIC DIMENSIONAL DATA UNLESS OTHERWISE SPECIFIED.
- APPLICABLE STANDARDS:  
 ASME Y14.41-2003 APPLIES TO DATASET.  
 ASME Y14.5M-1994 APPLIES TO DIMENSIONING AND TOLERANCING.
- $\square .06 \square A \square B \square C$  APPLIES TO ALL UNTOLERANCED SURFACES.
- DIMENSIONING AND TOLERANCING APPLY WITH PART RESTRAINED AS FOLLOWS, EXCEPT AS INDICATED.  
 PLACE DATUM FEATURE A AGAINST DATUM FEATURE SIMULATOR A.  
 ENGAGE DATUM FEATURES B AND C WITH DATUM FEATURE SIMULATORS B AND C RESPECTIVELY.  
 APPLY LOAD TO PART TO RESTRAIN DATUM FEATURE A AGAINST ITS SIMULATOR.  
 DETAILED INSPECTION PLAN NEEDED TO COMPLETELY DEFINE RESTRAINT.
- UNITS: INCHES

Feature and Specification Index  
**R50J**

PMI Fully-Toleranced Test Case 8 - View A  
 Includes Atomic Test Cases - 66, 90

Rev C

nist\_ftc\_08\_asme1\_rc

### NIST PMI Test Models - 2014

NOTES (UNLESS OTHERWISE SPECIFIED):

- CAD MODEL \_\_\_\_\_ REV. \_\_\_\_ IS REQUIRED TO COMPLETE PRODUCT DEFINITION.
- DIRECTLY-TOLERANCED DIMENSIONS AND BASIC DIMENSIONS DEFINED ON THE DRAWING TAKE PRECEDENCE OVER DIMENSIONAL DATA DEFINED BY THE MODEL. OBTAIN ALL OTHER DIMENSIONAL DATA FROM THE MODEL. THE MODEL REPRESENTS BASIC DIMENSIONAL DATA UNLESS OTHERWISE SPECIFIED.
- APPLICABLE STANDARDS:  
 ASME Y14.41-2003 APPLIES TO DATASET.  
 ASME Y14.5M-1994 APPLIES TO DIMENSIONING AND TOLERANCING.
- DIMENSION AND TOLERANCE VALUES SHOWN IN SQUARE BRACKETS [XXX] ARE MILLIMETERS.
- MATERIAL: (.1195 THICK) 11 GA 304 SST SHT, ASTM A240.
- UNITS: INCHES

Feature and Specification Index  
**R50J**

PMI Fully-Toleranced Test Case 9 - View A  
 Includes Atomic Test Cases - 59, 61

Rev D

nist\_ftc\_09\_asme1\_rd



### NIST PMI Test Models - 2014

R50J

NOTES (UNLESS OTHERWISE SPECIFIED):

- CAD MODEL \_\_\_\_\_ REV. \_\_\_ IS REQUIRED TO COMPLETE PRODUCT DEFINITION.
- DIRECTLY-TOLERANCED DIMENSIONS AND BASIC DIMENSIONS DEFINED ON THE DRAWING TAKE PRECEDENCE OVER DIMENSIONAL DATA DEFINED BY THE MODEL. OBTAIN ALL OTHER DIMENSIONAL DATA FROM THE MODEL. THE MODEL REPRESENTS BASIC DIMENSIONAL DATA UNLESS OTHERWISE SPECIFIED.
- APPLICABLE STANDARDS:  
 ASME Y14.41-2003 APPLIES TO DATASET AND MOVABLE DATUM TARGETS.  
  
 ASME Y14.5M-1994 APPLIES TO DIMENSIONING AND TOLERANCING.
- FULL DIAMETER OF EACH INDICATED HOLE MUST INTERSECT WITH THE CROSS-DRILLED HOLE AT ITS BOTTOM. INDICATED HOLES MUST NOT CONTACT FAR SIDE OF CROSS-DRILLED HOLES.
- $\text{1.5} \text{ [A] [B] [C]}$  APPLIES TO ALL UNTOLERANCED SURFACES.
- UNITS: MILLIMETERS

PMI Fully-Toleranced Test Case 10 - View A  
 Includes Atomic Test Cases - N/A

Rev B

nist\_fic\_10\_asme1\_rb

### NIST PMI Test Models - 2014

R50J

NOTES (UNLESS OTHERWISE SPECIFIED):

- CAD MODEL \_\_\_\_\_ REV. \_\_\_ IS REQUIRED TO COMPLETE PRODUCT DEFINITION.
- DIRECTLY-TOLERANCED DIMENSIONS AND BASIC DIMENSIONS DEFINED ON THE DRAWING TAKE PRECEDENCE OVER DIMENSIONAL DATA DEFINED BY THE MODEL. OBTAIN ALL OTHER DIMENSIONAL DATA FROM THE MODEL. THE MODEL REPRESENTS BASIC DIMENSIONAL DATA UNLESS OTHERWISE SPECIFIED.
- APPLICABLE STANDARDS:  
 ASME Y14.41-2003 APPLIES TO DATASET.  
  
 ASME Y14.5M-1994 APPLIES TO DIMENSIONING AND TOLERANCING.
- NON-RIGID PART. DIRECTLY-TOLERANCED DIMENSIONS AND TOLERANCES APPLY IN FREE STATE.
- UNITS: MILLIMETERS

PMI Fully-Toleranced Test Case 11 - View A  
 Includes Atomic Test Cases - 55, 100

Rev B

nist\_fic\_11\_asme1\_rb